

# Direct Operated Precision Regulator Modular Style

## Series *ARP3000*

- Setting sensitivity: 0.001 MPa
- Can be connected as a module to a mist separator.  
(AFM30 + ARP3000)  
(AFD30 + ARP3000)
- Direct-driven, bleed type  
(With relieving function)



ARP3000-02



ARP3000-02BG

JIS Symbol

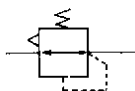

### Standard Specifications

Model	ARP3000
Port size	1/4
Fluid	Air
Proof pressure	1.2 MPa
Maximum operating pressure	0.8 MPa
Regulating pressure range	0.005 to 0.3 MPa
Setting sensitivity	0.001 MPa
Repeatability	±0.003 MPa
Air consumption <sup>Note)</sup>	4 to 6 l/min (ANR) (0.3 MPa)
Pressure gauge port size	1/8
Ambient and fluid temperature	-5 to 60°C (No freezing)
Construction	Bleed type
Weight (kg)	0.42

Note) Air consumption differs depending on the set pressure.

### Accessory (Option)/Part No.

Description	Part no.
Bracket	B320
Pressure gauge <sup>(1)</sup>	0.4 MPa G36-4-□01

- Note 1) • □ in the gauge part no. indicates the threads used for connection. For Rc, leave the symbol blank, and for NPT, enter "N".  
• Please contact SMC concerning the supply of NPT pressure gauges.
- Note 2) Use caution not to tighten excessively when mounting a pressure gauge, otherwise it will may result in a breakdown. (Fastening torque recommended: 7 to 9 N·m.) For sealing, use a pipe tape.

### How to Order

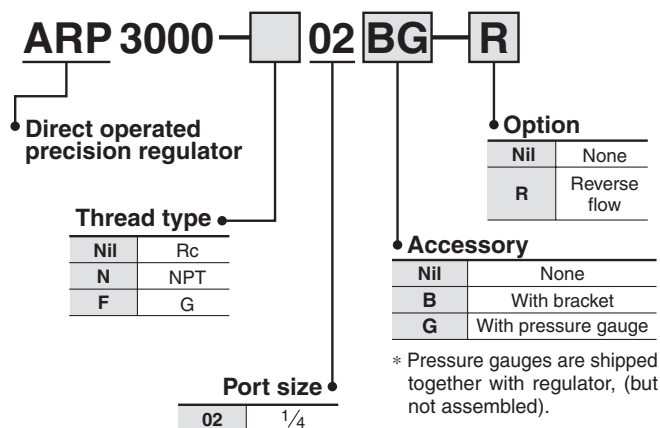

F.R.L.

AV

AU

AF

AR

IR

VEX

AMR

ITV

IC

VBA

VE□

VY1

G

PPA

AL

# Series ARP3000

## Construction

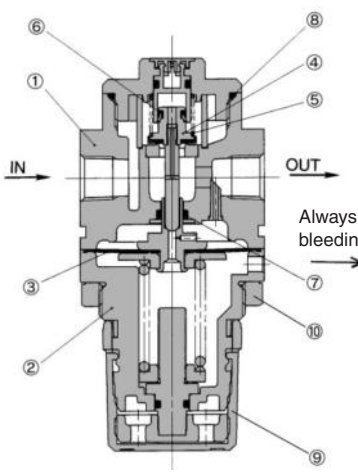

**JIS Symbol**

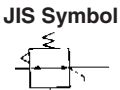

**Component Parts**

No.	Description	Material	Note
①	Body	Aluminum die-casted	Platinum silver painted
②	Bonnet	Aluminum die-casted	Black painted

**Replacement Parts**

No.	Description	Material	Part no.
③	Diaphragm assembly	Weather resistant NBR	1315510A
④	Valve assembly	Brass, HNBR	1315506A
⑤	Valve spring	Stainless steel	1315516-2
⑥	Valve mini Y packing	NBR	MYN-5
⑦	O-ring	NBR	JIS B 2401P6
⑧	O-ring	NBR	131545
⑨	Handle	Polyacetal	1315513
⑩	Set nut	Zinc die-casted	131532

## Dimensions

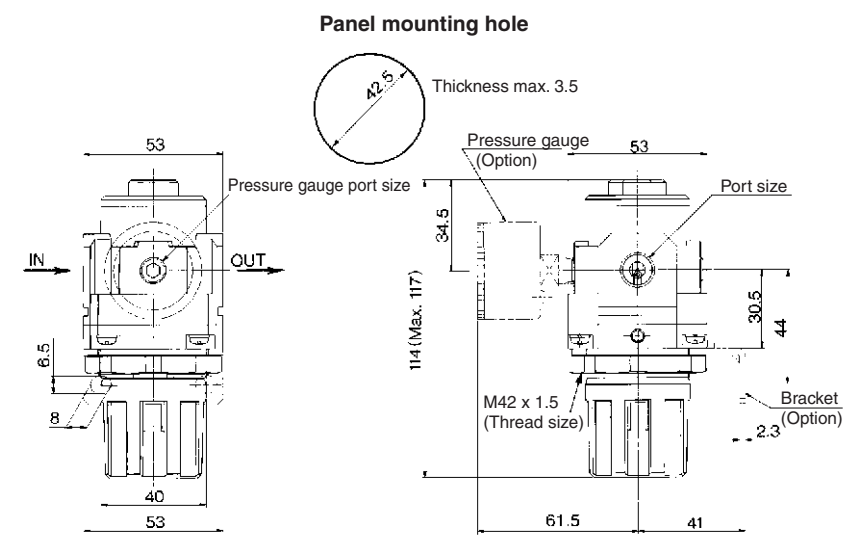

**Panel mounting hole**

Thickness max. 3.5

Pressure gauge port size

Port size

Pressure gauge (Option)

Bracket (Option)

M42 x 1.5 (Thread size)

\* For products with pressure gauge, pressure gauge is shipped together with product.

Set nut: Width across flats 50

## Pressure Characteristics

Inlet pressure: 0.5 MPa  
Outlet pressure: 0.2 MPa  
Flow rate: 0 ℓ/min (ANR)

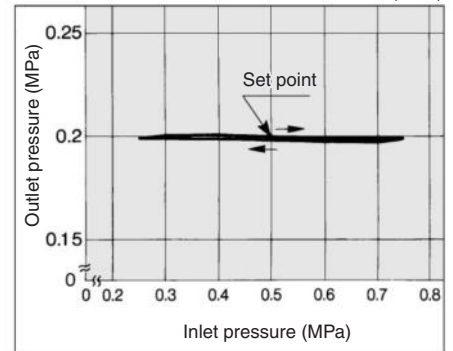

## Flow Characteristics

Inlet pressure: 0.7 MPa

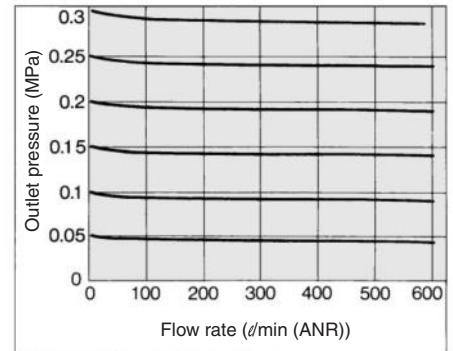

## ⚠ Caution

1. Release the lock to adjust the pressure. After the adjustment, engage the lock.

Failure to observe this procedure could damage the handle or cause the outlet pressure to fluctuate.

- 1) Pull the adjustment handle to release the lock. (An orange colored line is provided at the bottom of the adjustment handle for visual checking.)

Push the adjustment handle to engage the lock. If it does not lock easily, turn the handle slightly clockwise or; then, push it until the orange colored line is no longer visible.

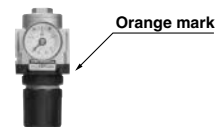

## ⚠ Precautions

Be sure to read before handling. Refer to pages 14-21-3 to 14-21-4 for Safety Instructions and Common Precautions.

### Selection

#### ⚠ Caution

1. Set the output pressure to 90% or less of the inlet pressure.  
Failure to observe this procedure could result in an excessive pressure drop.

### Air Supply

#### ⚠ Warning

1. Use a mist separator on the inlet side. If the air contains drain or debris, it could clog the bleed holes and lead to a malfunction.
2. Do not use a lubricator on the inlet side because it could clog the bleed holes and lead to a malfunction.

- 2) Install the valve guide (on the opposite side of the handle) 60 mm away from the ground surface. Maintenance and inspection will be facilitated.
- 3) Air is normally released from the bleed hole.  
This is necessary for direct-operated precision regulator construction.
- 4) Please contact SMC if this product is to be used between solenoid valve and actuator.
- 5) Fasten the main body with a set nut tightly and fix it.  
Recommended torque for set nut:  $22.5 \pm 4.5$  N·m

# Regulator for 2 MPa *Series ARX20*

2.0 MPa compatible, piston type regulator



- Compatible with inlet supply pressure of 2.0 MPa
- Compact type (face to face dimensions 35 mm, overall length 80 mm)
- Piston type
- 3 out ports for convenient use
- Employs a handle shape for easy operation
- Ideal for discharge pressure adjustment on a small compressor
- Ideal for pressure adjustment of air blowing applications

F.R.L.

AV

AU

AF

**AR**

IR

VEX

AMR

ITV

IC

VBA

VE□

VY1

G

PPA

AL

# Regulator for 2 MPa

## Series ARX20

### How to Order

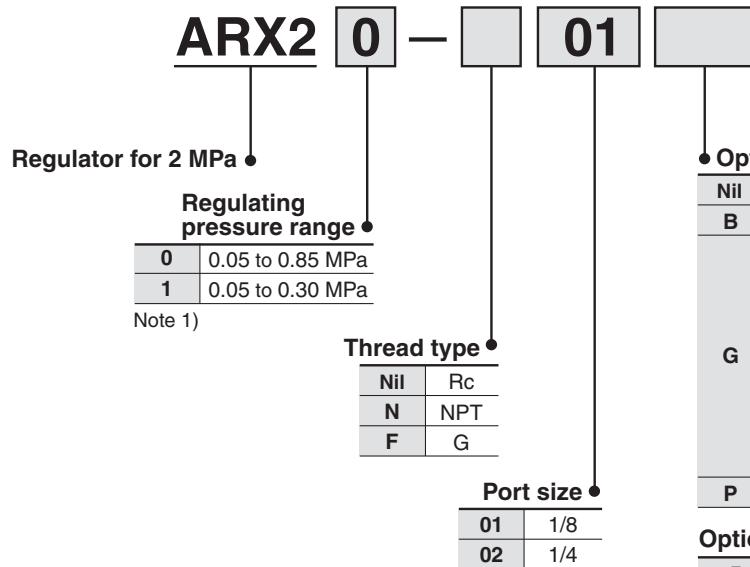

#### Option

Nil	None		
B	Bracket	1348112	
G	Pressure gauge <sup>(2)</sup>	ARX20- <input type="checkbox"/> Nil- <input type="checkbox"/> F	G36-10-01 G46-10-02
		ARX21- <input type="checkbox"/> Nil- <input type="checkbox"/> F	G36-4-01 G46-4-02
		ARX20-N <input type="checkbox"/>	G36-P10-N01 G46-P10-N02
		ARX21-N <input type="checkbox"/>	G36-P4-N01 G46-P4-N02
P	Panel nut	1348110A	

#### Option combination numbers

B	BG	* Panel nut is also included with B.
G	GP	
P		

Note 1) Compared with ARX20, ARX21 is the product which adjusting spring has only been changed. It is not the product, which does not allow the pressure more than 0.3 MPa.

Note 2) Pressure gauges are shipped together, (but not assembled).

### Specifications



Model	ARX20	
Regulator construction	Piston type regulator	
Relief mechanism	Relieving type	
Port size	Rc 1/8, 1/4	
Pressure gauge port size	Rc 1/8, 1/4	
Proof pressure	3.0 MPa	
Maximum operating pressure	2.0 MPa	
Regulating pressure range	Standard type	0.05 to 0.85 MPa
	Low pressure type	0.05 to 0.3 MPa
Fluid	Air	
Ambient and fluid temperature	-5 to 60°C (No freezing)	
Weight	110 g	

#### JIS Symbol

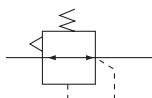

# Regulator for 2 MPa Series ARX20

## Flow Characteristics

Inlet pressure: 2.0 MPa

**ARX20-01**

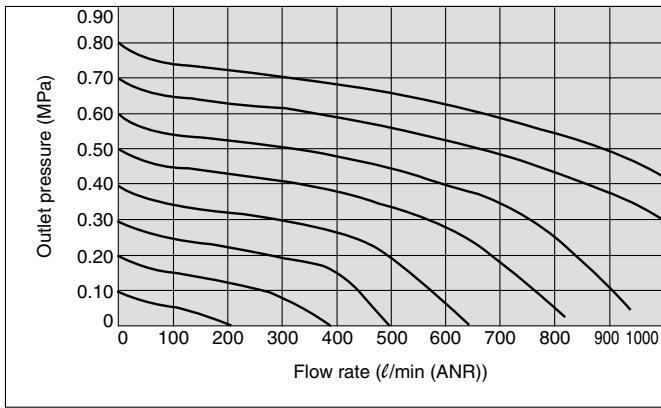

**ARX20-02**

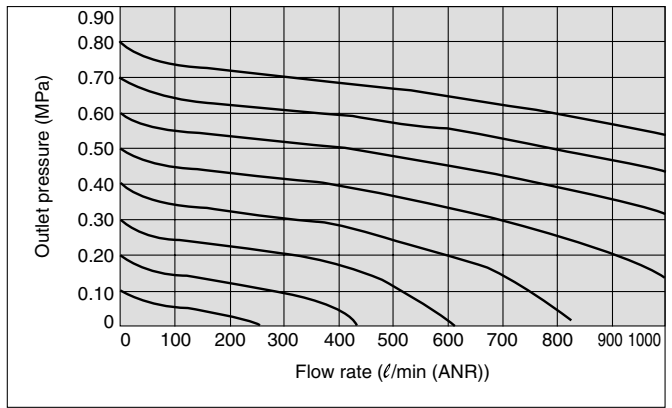

**ARX21-01**

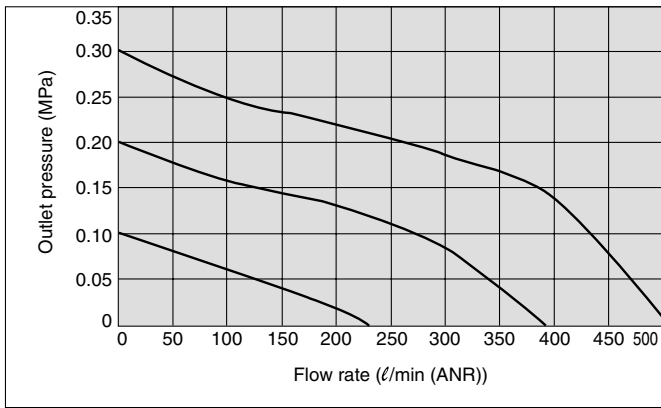

**ARX21-02**

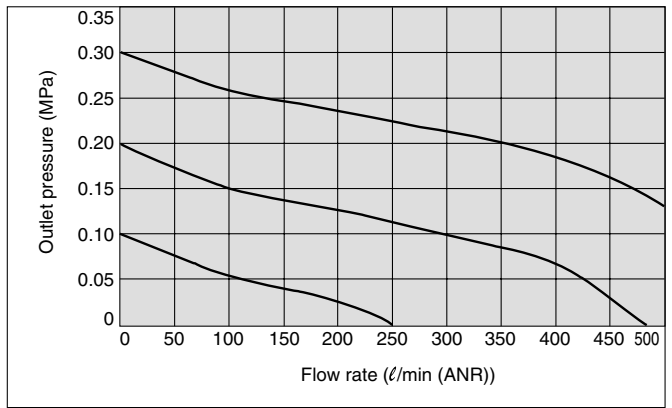

F.R.L.

AV

AU

AF

AR

IR

VEX

AMR

ITV

IC

VBA

VE□

VY1

G

PPA

AL

## Pressure Characteristics

**ARX20**

Inlet pressure: 2.0 MPa  
Outlet pressure: 0.8 MPa  
Flow rate: 60 ℓ/min (ANR)

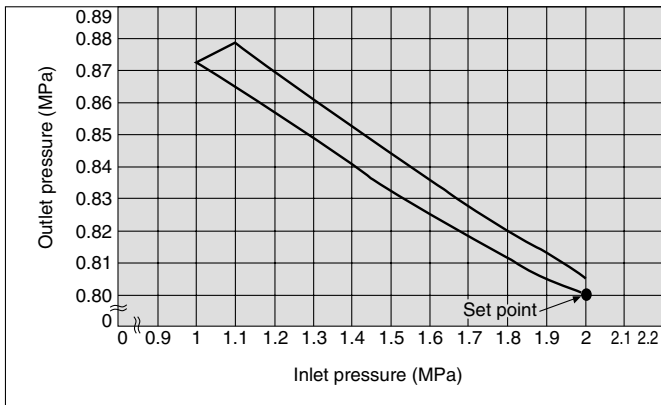

**ARX21**

Inlet pressure: 2.0 MPa  
Outlet pressure: 0.3 MPa  
Flow rate: 60 ℓ/min (ANR)

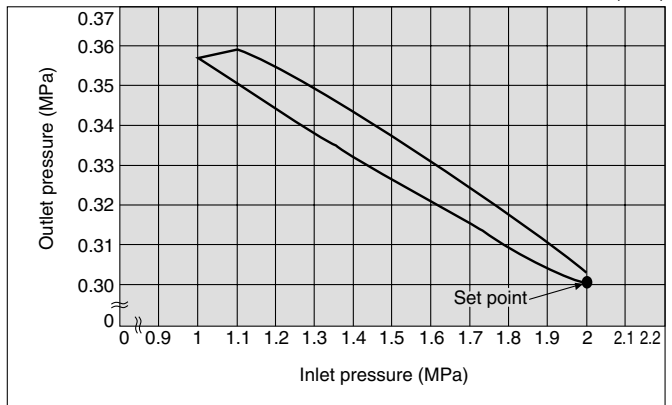

# Series ARX20

## Construction

JIS Symbol

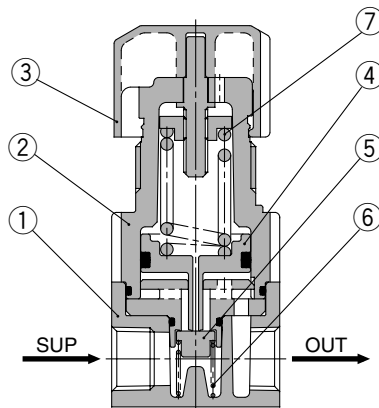
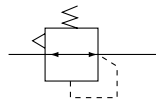

### Component Parts

No.	Description	Material	Note
①	Body	ADC	
②	Bonnet	POM	

### Replacement Parts

No.	Description	Material	Part no.
③	Handle	POM	1348102#1
④	Piston assembly	POM, NBR	1348104A
⑤	Valve	Brass, NBR	1348105
⑥	Valve spring	Stainless steel	1348109
⑦	Adjusting spring	Steel wire	1348108 (For 0.85 MPa) 1348108-1 (For 0.3 MPa)

## Dimensions

