

Water Cooled Aftercooler

Series HAW

Series HAW can cool high temperature compressed air from compressors down to 40°C or less and efficiently remove moisture from the air.

As series HAW is water-cooled, it can be used where there is high temperature, high moisture and heavy foreign particles.

25 times heat transfer area

As compared to shell and bare tube, the flower fin tube has 25 times the heat transfer area.

Even heat exchange

Sharp edge of flower fin causes air turbulence resulting in even heat exchange and high cooling efficiency.

Compact size (1/2 to 1/3)

Compared to conventional coolers, the size is cut by 1/2 to 1/3, resulting in reduced installation space.

High efficiency drain

Drainage is efficiently removed by built-in drain separator.

Visible outlet air temperature

Outlet air temperature is easily checked by thermometer, resulting in easy maintenance.



JIS Symbol

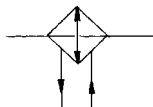

Model/Standard Specifications

Model		HAW2	HAW7	HAW22	HAW37	HAW55	HAW75	HAW110	
Applicable compressor (kW)	Screw type compressor	2.2	7.5	22	37	55	75	110	
	Reciprocating type compressor	2.2	7.5	15	22	37	55	75	
Air flow rate ⁽¹⁾ ℓ /min(ANR)	Screw type compressor	300	1000	3300	5700	8600	12000	18000	
	Reciprocating type compressor	300	1000	2100	4300	5600	8000	11000	
Rated performance	Inlet air temperature (°C)	Screw type compressor	70						
		Reciprocating type compressor	70	180					
Inlet air pressure dew point (°C)		67							
Inlet air pressure (MPa)		0.7							
Cooling water flow (ℓ /min)		5	5	17	25	36	40	45	
Cooling water inlet temperature (°C)		30							
Outlet air temperature (°C)		40							
Cooling water pressure drop (MPa)		0.002		0.02		0.03	0.06	0.03	
Operating range	Fluid	Air: Compressed air, Cooling water: Industrial water/Fresh water							
	Inlet air temperature (°C)	5 to 100			5 to 200				
	Inlet air pressure (MPa)	0.05 to 1.0 (With auto-drain: 0.15 to 1.0)			0.05 to 0.97 (With auto-drain: 0.15 to 0.97)				
	Ambient temperature (°C)	2 to 50							
Proof pressure (MPa)		1.5							
Port size	Air side	Rc 1/2	Rc 3/4	Rc 1 1/2	Rc 2		3B flange		
	Cooling water side	Rc 1/2		Rc 3/4	Rc 1			Rc 1 1/4	
	Drain side	Rc 1/2		Rc 3/4			Rc 1		
Weight (kg)		9.7	11.5	32	59	67	78	95	
Coating color		Silver							
Accessory ⁽²⁾	Drain valve (1 pc.)	Rc 1/2		Rc 3/4			Rc 1		
	Outlet air thermometer (1 pc.)	●							

Note 1) ANR indicates the flow rate converted to the value at 20°C under the atmospheric pressure and the state of relative humidity 65%.

Note 2) The accessories should be mounted by user.

Accessory (Option)

Applicable model	HAW2	HAW7	HAW22	HAW37	HAW55	HAW75	HAW110
Screw flange (With companion flange)	—	—	HAWF-141	HAWF-142	HAWF-200	HAWF-200	—
Auto-drain	AD402-04		AD600-06			AD600-10	

Model Selection (Flow Capacity ℓ /min (ANR))

Model		HAW2-04	HAW7-06	HAW22-14	HAW37-14	HAW55-20	HAW75-20	HAW110-30
Inlet air temperature	50°C	1000	2000	6000	12000	15000	22000	30000
	70°C	300	1000	3300	5700	8600	12000	18000
	100°C	150	700	2500	5000	7000	10500	14000
	180°C	—	—	2100	4300	5600	8000	11000

Conditions: • Supply pressure 0.7 MPa, Outlet air temperature 40°C, Cooling water inlet temperature 30°C.
• Inlet air temperature 50°C is saturated air. At 70°C or more, it is humid air with dew point 67°C.

HA□

AT

ID□

AMG

AFF

AM□

Misc.

Series HAW

How to Order

HAW 22-14 D

Basic size (Applicable compressor kW)

Symbol	Screw type	Reciprocating type
2		2.2
7		7.5
22	22	15
37	37	22
55	55	37
75	75	55
110	110	75

Accessory (Option)

F	With screw flange
D	With auto-drain

Port size

04	Rc 1/2	HAW2
06	Rc 3/4	HAW7
14	Rc 1 1/2	HAW22/37
20	Rc 2	HAW55/75
30	3 rd flange	HAW110

How to Calculate Outlet Air Temperature

Outlet air temperature can be calculated with inlet air temperature, cooling water temperature and amount of air in the following procedure.

(Example) Inlet air temperature: 100°C, Cooling water temperature: 20°C, Cooling water flow: 17 l/min
Air flow: 2000 l/min (ANR), Air pressure: 0.7 MPa, Model: HAW22-14

Outlet air temperature at above conditions

- Use outlet air temperature of 37°C from outlet air temperature table. At this time correction factor line becomes (A).
- To get correction factor of 1.3 use cooling water temperature correction factor (A) at 20°C.
- To get outlet air temperature divide 37°C from (1) by 1.3 from (2).
Outlet air temperature = 37 ÷ 1.3 = 28.5°C

Correction Factor by Cooling Water Temperature

Air pressure 0.7 MPa

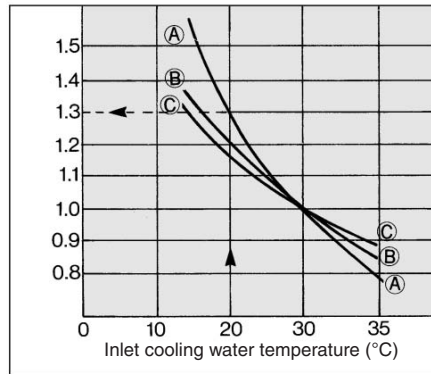

Outlet Air Temperature

Model	Cooling water (l/min)	Correction factor	Air flow (l/min (ANR))	Inlet air temperature			
				50°C	70°C	100°C	180°C
HAW2	5	(A)	200	35.5	38.5	41.5	—
		(B)	300	36	40	43	—
		(C)	400	36.5	42	45.5	—
HAW7	5	(A)	500	33.5	36	37	—
		(B)	1000	36	40	43	—
		(C)	1500	38	45.5	49.5	—
HAW22	17	(A)	2000	33.5	36	37	37.5
		(B)	3300	36	40	43	47
		(C)	4000	36.5	42.5	45.5	51
HAW37	25	(A)	4000	33.5	36	37	38
		(B)	5700	35	40	42	44.5
		(C)	7000	36	41	43.5	48
HAW55	36	(A)	7000	34.5	38	40	43
		(B)	8600	36	40	44	49
		(C)	10000	37	42.5	46	54
HAW75	40	(A)	10000	34.5	38	39.5	42
		(B)	12000	35.5	40	43	47
		(C)	14000	36	41.5	44.5	49.5
HAW110	45	(A)	15000	34.5	39	41	45
		(B)	18000	35.5	40	43	48.5
		(C)	20000	36	42.5	45.5	52

Conditions: • Air pressure 0.7 MPa, Cooling water temperature 30°C
• Inlet air temperature 50°C is saturated air. At 70°C or more, it is humid air with dew point 67°C.

Precautions

Be sure to read before handling. Refer to pages 14-21-3 to 14-21-4 for Safety Instructions and Common Precautions on the products mentioned in this catalog, and refer to pages 14-14-6 to 14-14-8 for precautions on every series.

Caution on Design

Warning

- If the supply of coolant water is disrupted, the system will overheat, creating a dangerous situation. Therefore, make sure to take safety measures against water failure.
- An excess or insufficient flow of coolant water can damage the heat exchanger tube. Therefore, design within the rated water flow range (refer to the model column).

Caution

- Design the piping for coolant water and compressed air with a bore that is greater than the bore of the piping connections.
- The quality of the coolant water to be used must exceed the water quality that has been specified by the Japan Refrigeration and Air Conditioning Industry Association. (Refer to the instruction manual.) Poor quality coolant water damages the heat exchanger and reduces performance. Therefore, inspect the water quality and replace the circulating water on a regular basis.
- Never use sea water for cooling.

Mounting

Caution

- Install the unit horizontal with pipe line.
- Make sure to correctly connect the compressed air inlet/outlet and the coolant water inlet/outlet.
- Use union joints to connect the coolant water pipes so that they can be easily removed during maintenance.
- Connect a drain pipe because a large amount of drainage is created when the compressed air is cooled. The drain pipe must have a minimum pipe bore of 10 mm, and a maximum length of 5 m (when installing an optional auto drain).

Maintenance

Caution

- Inspect the quality of the coolant water and replace the circulating water on a regular basis. If the coolant water is cooled in a cooling tower, it is susceptible to the adhesion of water scale.
- If there is a likelihood that the coolant water will be frozen, drain the coolant water to prevent damage. Also, drain the coolant water when the equipment will not be used for a long period of time.
- If the cooling performance has been reduced, clean the inside of the coolant water pipes. (Refer to the instruction manual for details on the cleaning.)

Water Cooled Aftercooler Series HAW

Construction Principle

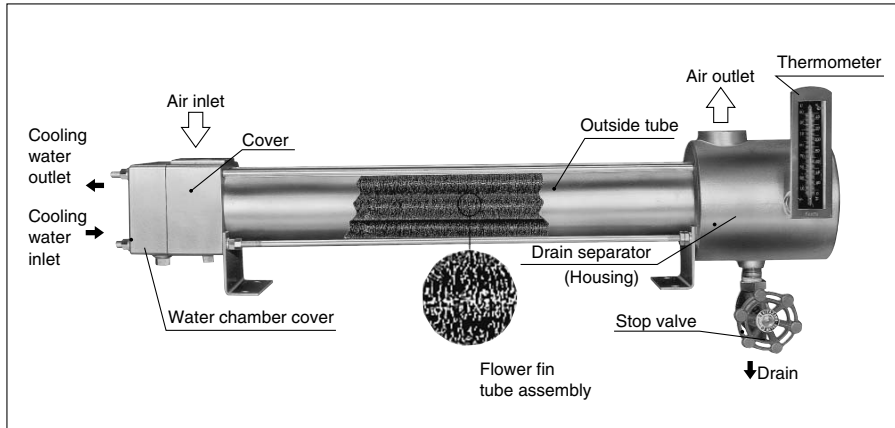

Flow Characteristics Air pressure 0.7 MPa

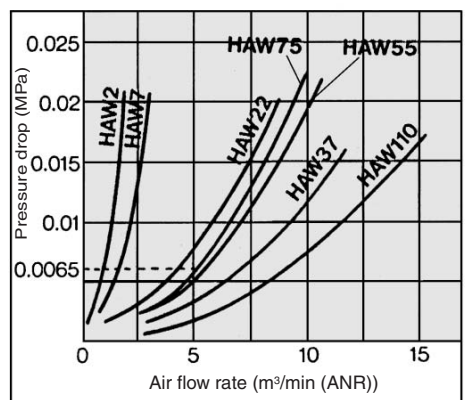

(Example) To get pressure drop at 0.3 MPa of air pressure, 5 m³/min (ANR) of air flow and model HAW75-20, use 0.0065 MPa at 0.7 MPa from the table and convert P1 to 0.3 MPa.

$$\text{Pressure drop} = \frac{(0.7 + 0.1013) \times \Delta P}{P_1 + 0.1013} = \frac{0.8013 \times 0.0065}{0.3 + 0.1013} = 0.013 \text{ MPa}$$

Construction

HAW2/7

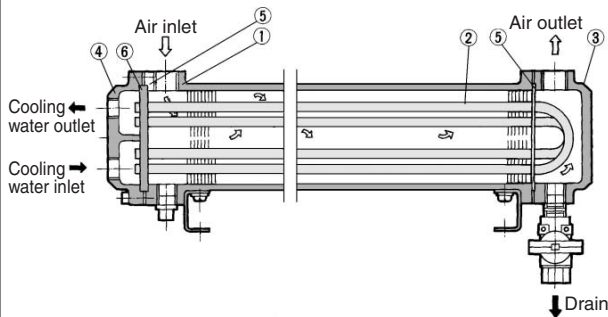

HAW22 to 110

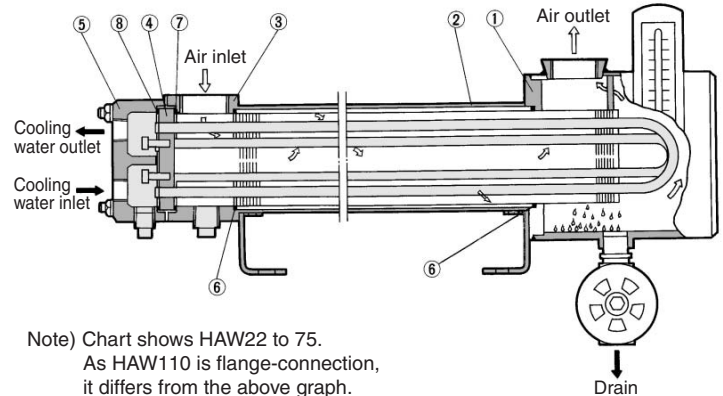

Component Parts (HAW2/7)

No.	Description	Material	Note
①	Outside tube	AC2A-F	—
②	Flower fin tube assembly	C1220T	Flower fin
③	Housing	AC2A-F	—
④	Water chamber cover	FC200	—

Replacement Parts

No.	Description	Material	HAW2	HAW7
②	Flower fin tube assembly	Aluminum Copper, Carbon steel	42012	42022
⑤	Packing	Non-asbestos	42013	42013
⑥	Packing	Non-asbestos	42015	42015

Component Parts (HAW22 to 110)

No.	Description	Material	Note
①	Housing	SGP, SS400	—
②	Outside tube	STK	—
③	Body	FC200	—
④	Flower fin tube assembly	C1220T	Flower fin
⑤	Water chamber cover	FC200	—

Replacement Parts

No.	Description	Material	HAW22	HAW37	HAW55	HAW75	HAW110
④	Flower fin tube assembly	Aluminum Copper Carbon steel	42036	42046	42054	42062	42073
⑥	Packing	V # 6401	42032	42042	42042	42042	—
⑦	Packing	V # 6401	42035	42045	42045	42045	42072
⑧	Packing	V # 6401	42037	42047	42047	42047	42074

- HA
- AT
- ID
- AMG
- AFF
- AM
- Misc.

Series HAW

Dimensions

HAW2/7

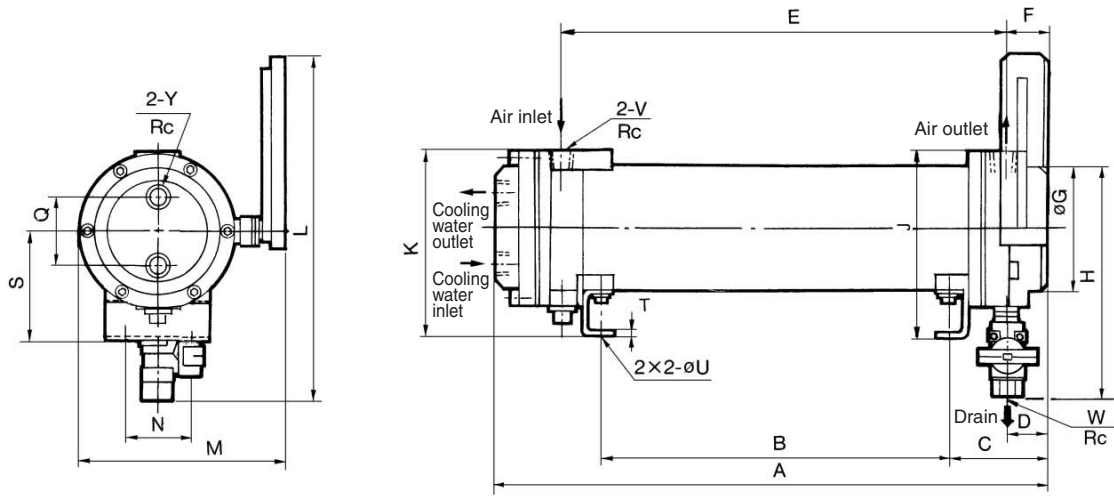

HAW22 to 110

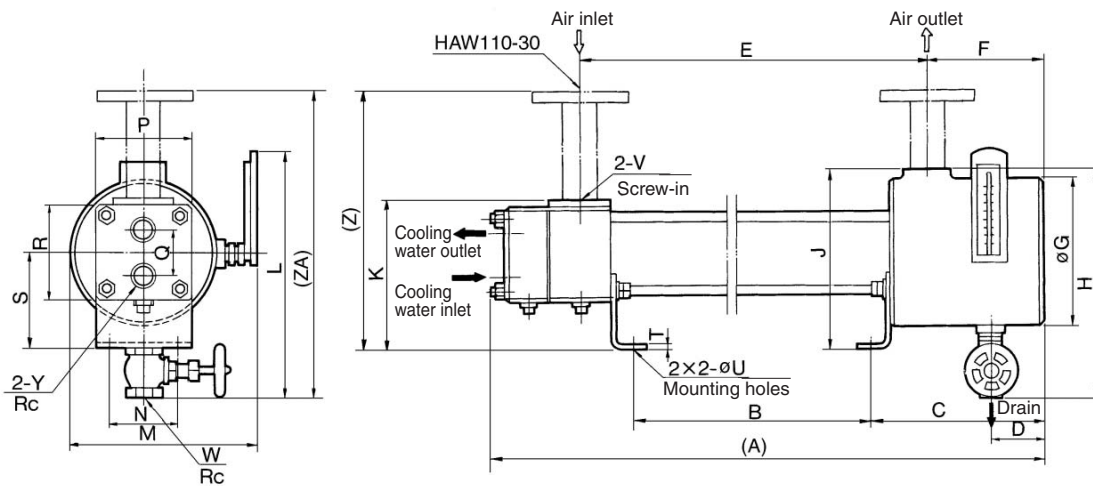

Model	A	B	C	D	E	F	øG	H	J	K	L	M	N	P	Q	R	S	T	øU	V	W	Y	Z	ZA
HAW2-04	360	190	83	35	270	35	130	203	159	159	293	193	60	—	60	—	94	4.5	10	1/2	1/2	1/2	—	—
HAW7-06	570	390	83	35	480	35	130	203	159	159	293	193	60	—	60	—	94	4.5	10	3/4	1/2	1/2	—	—
HAW22-14	948	575	212	37	704	138	165	266	245	215	326	238	90	120	60	120	150	4.5	12	1 1/2	3/4	3/4	—	—
HAW37-14	1354	893	258	80	1056	170	216	324	264	219	354	289	100	140	66	140	139	6.0	18	1 1/2	3/4	1	—	—
HAW55-20	1612	1038	366	150	1203	276	216	324	264	219	354	289	100	140	66	140	139	6.0	18	2	3/4	1	—	—
HAW75-20	2112	1538	366	150	1703	276	216	324	264	219	354	289	100	140	66	140	139	6.0	18	2	3/4	1	—	—
HAW110-30	1724	950	500	72	1210	365	267.3	473	—	—	428	357	200	220	70	—	195	8.0	18	3	1	1 1/4	395	473