



# Super Mist Separator

## Series AME

Series AME separates and absorbs aerosol state fine oil particles in compressed air and changes the oil lubricating compressed air to oilless equivalent air.

It should be applied for filtration of compressed air requiring high cleanliness for coating lines, compressed air for clean rooms and compressed air for equipment that must avoid oils.

Due to its special configuration, Series AME indicates the life of the filter element by a color change. Accordingly, the replacement time can be judged visually. (A red color spot indicates the replacing time.)

By all means Series "AM" should be used as a prefilter. Additionally the Series "AMF" in the rear stage can produce high quality compressed air as an air source for clean rooms.



JIS Symbol  
AME



P. 14-20-57

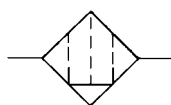

### Caution

Be sure to read before handling. Refer to pages 14-21-3 to 4 for Safety Instructions and Common Precautions on the products mentioned in this catalog, pages 14-14-6 to 8 for Precautions on every series, and pages 14-20-62 to 64 for more detailed precautions on every series.

### Model

Model	AME150	AME250	AME350	AME450	AME550	AME650	AME850
Rated flow (l/min (ANR)) <small>Note)</small>	200	500	1000	2000	3500	6000	12000
Port size (Nominal size B)	1/8, 1/4, 3/8	1/4, 3/8, 1/2	3/8, 1/2, 3/4	1/2, 3/4, 1	3/4, 1	1, 1 1/2	1 1/2, 2
Weight (kg)	0.38	0.55	0.9	1.4	2.1	4.2	10.5



Note) Max. flow capacity at a pressure of 0.7 MPa.  
Max. flow varies depending on operating pressure.  
Refer to "Flow Characteristics" (page 14-20-38)  
and figure of "Max. Air Flow" (page 14-20-38).

### Specifications

Fluid	Compressed air
Max. operating pressure	1.0 MPa
Min. operating pressure	0.05 MPa
Proof pressure	1.5 MPa
Ambient and fluid temperature	5 to 60°C
Filtration	0.01 μm (95% particle size collection)
Oil mist removal rate	Less than 3.5 particles 0.3 μm or larger per liter of air (100 particles or less per cubic foot)
Element life	Element color indicator (When an element becomes saturated with oil the element surface changes from white to red.)



Refer to "Made to Order Specifications" on page 14-20-57.

### Accessory (Option)

Applicable model	AME150	AME250	AME350	AME450	AME550	AME650	AME850
Bracket assembly (With cap bolt and spring washer)	BM51	BM52	BM53	BM54	BM55	BM56	BM57

### How to Order

AME 250 03 B R

#### Body size

150	1/8 Standard
250	1/4 Standard
350	3/8 Standard
450	1/2 Standard
550	3/4 Standard
650	1 Standard
850	1 1/2 Standard

#### Option specifications

R IN-OUT reversal direction

#### Accessory (Option)

Nil	Nil
B	Bracket

#### Port size

01	1/8 <sup>B</sup>
02	1/4 <sup>B</sup>
03	3/8 <sup>B</sup>
04	1/2 <sup>B</sup>
06	3/4 <sup>B</sup>
10	1 <sup>B</sup>
14	1 1/2 <sup>B</sup>
20	2 <sup>B</sup>

#### Thread type

Nil	Rc
F	G
N	NPT

HA

AT

ID

AMG

AFF

AM

Misc.



Note) Refer to "How to Order Bowl Assembly" on page 14-20-59.

# Series AME

## Flow Characteristics

Element initial condition

Note) Compressed air over max. flow line in the table below may not meet the specifications of the product. It may cause damage to the element.

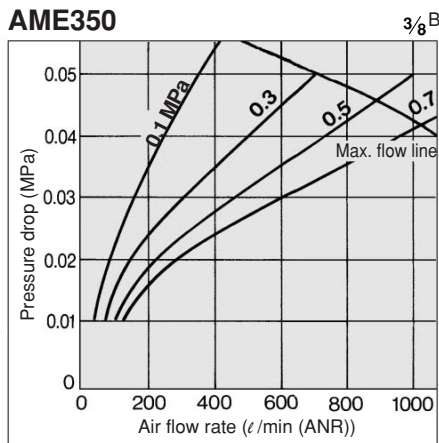
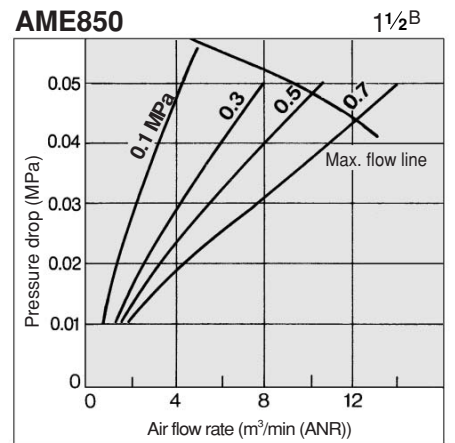
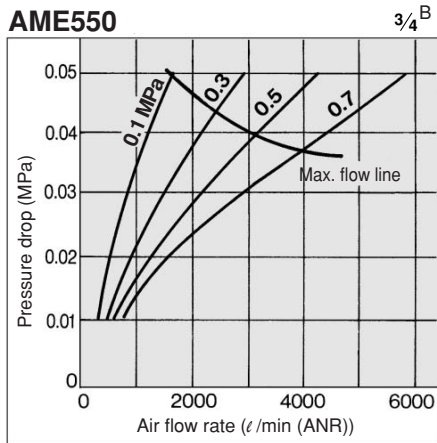
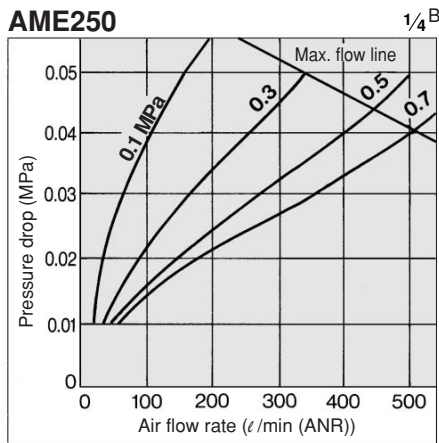
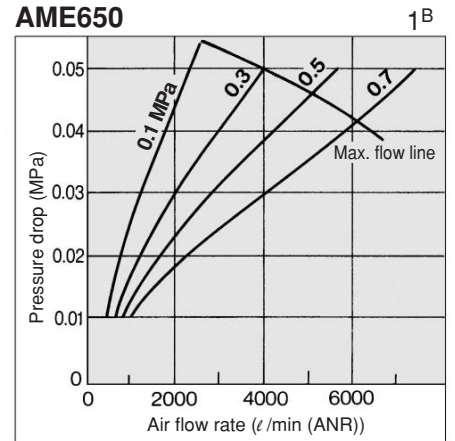
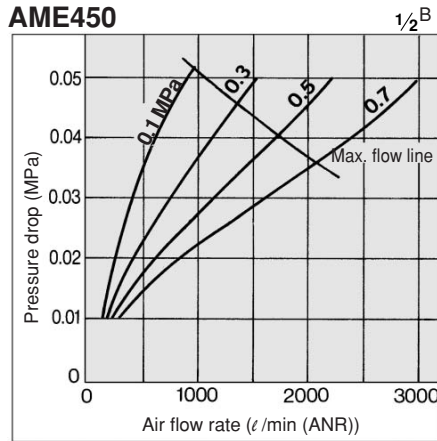
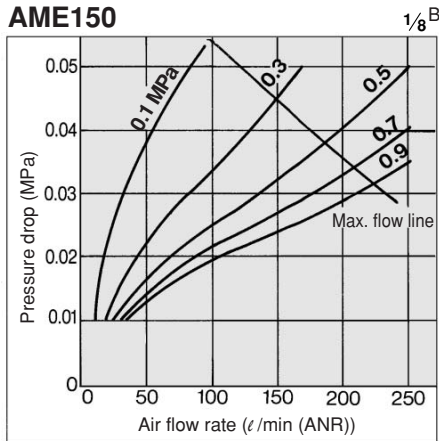

### Max. Air Flow

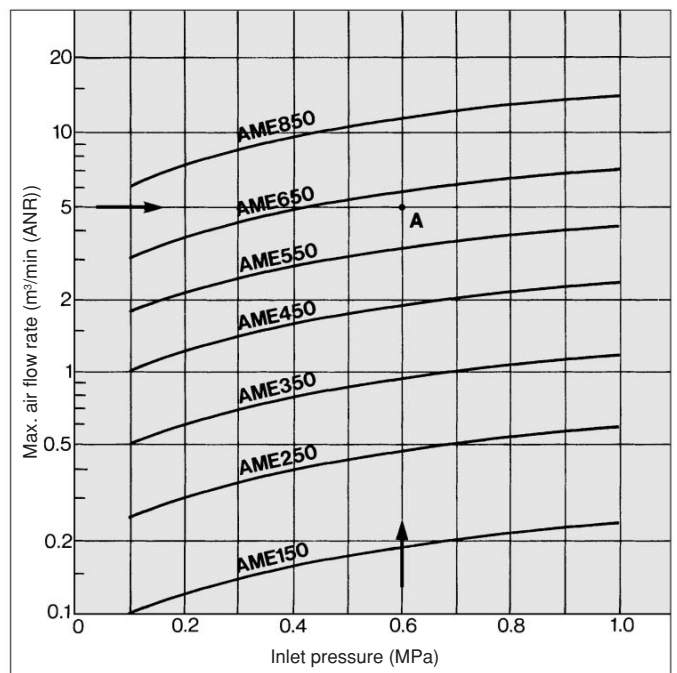

## Model Selection

Select the model in accordance with the following procedure taking the inlet pressure and max. air flow into consideration.

(Example) Inlet pressure: 0.6 MPa  
Max. air flow capacity: 5 m<sup>3</sup>/min (ANR)

1. Select the point of contact A of inlet pressure and max. air capacity in the graph.
2. AME650 is obtained when the max. flow line is above the point of intersection A in the graph.

Note) Make sure to select a model that has the maximum flow rate line above the obtained intersecting point. With a model that has the maximum flow rate line below the obtained intersecting point, the flow rate will be exceeded, thus leading to a problem such as being unable to satisfy the specifications.

# Super Mist Separator Series AME

## Construction

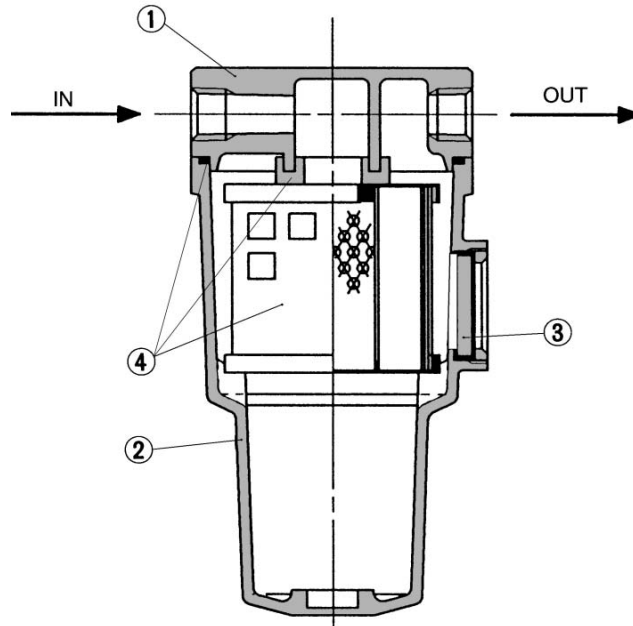

### Component Parts

No.	Description	Material	Note
①	Body	Aluminum die-casted	Chrome treated
②	Housing	Aluminum die-casted*	Epoxy coating on inner surface
③	Sight glass	Tempered glass	—



Note: Refer to page 14-20-59 for "How to Order Bowl Assembly".



Note: Sight glass is indicated in the figure above for easy understanding of parts, however mounting position is different. Refer to dimensions on pages 14-20-40 to 14-20-41 for details.

### Replacement Parts

\* AM850 is aluminum casted.

No.	Description	Material	Model						
			AME150	AME250	AME350	AME450	AME550	AME650	AME850
④	Element assembly	Glass fiber, Others	AME-EL150	AME-EL250	AME-EL350	AME-EL450	AME-EL550	AME-EL650	AME-EL850

\* Element assembly: With gasket and O-ring

HA

AT

ID

AMG

AFF

AM

Misc.

# Series AME

## AME150 to AME350 Dimensions

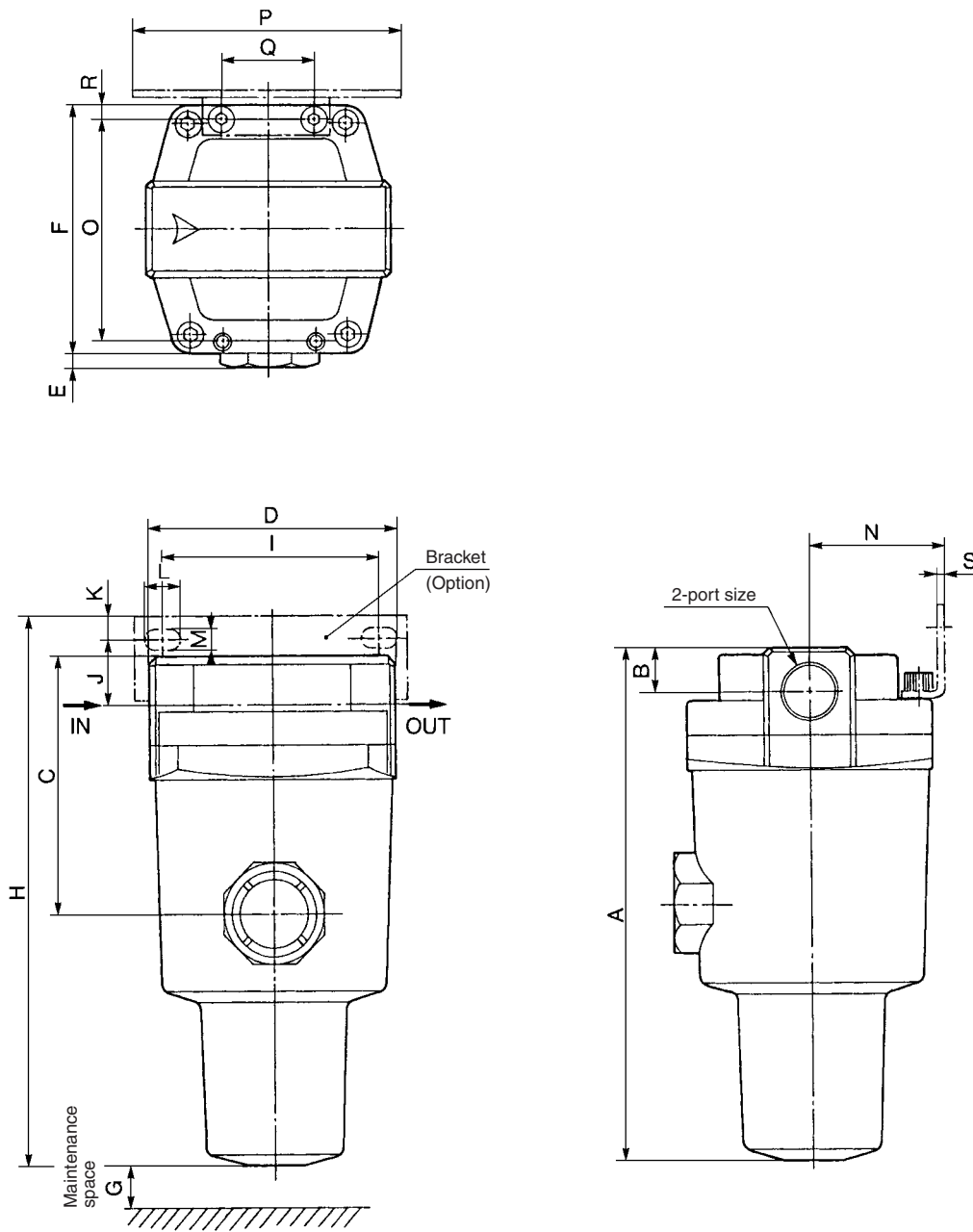

Model	Port size (Nominal size B)	A	B	C	D	E	F	G	Dimensions with mounting bracket											
									H	I	J	K	L	M	N	O	P	Q	R	S
AME150	1/8, 1/4, 3/8	139	13	55	63	7.5	63	10	146	56	15	5	9	5.5	35	54	70	26	4.5	1.6
	1/4, 3/8	152	13	66	76	4	76	10	167	66	20	8	12	6	40	66	84	28	5	2.0
AME250	1/2	158	16	72	76	4	76	10	167	66	17	8	12	6	40	66	84	28	5	2.0
	3/8, 1/2	184	16	92	90	5	90	10	198	80	22	8	14	7	50	80	100	34	5	2.3
AME350	3/4	190	19	98	90	5	90	10	198	80	19	8	14	7	50	80	100	34	5	2.3

