

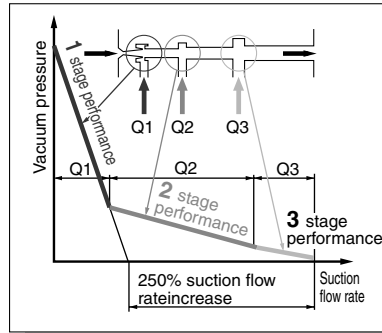

# Multistage Ejector Series ZL112/212

Energy-saving, large flow rate, 3 stage diffuser construction

Suction flow rate increased 250% and air consumption reduced 20% with 3 stage diffuser construction (Versus ø1.3, one stage model)



Design Award Winner 2000

	Maximum suction flow rate (ℓ/min (ANR))	Air consumption (ℓ/min (ANR))
ZL112	100	63
ZL212	200	126

## Series ZL212

Diffusers stacked and integrated  
Compact size and large flow rate  
(Twice the flow rate of the ZL112)

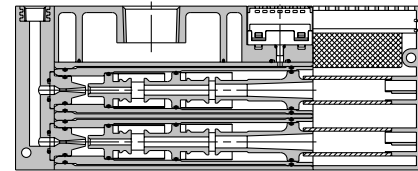

Series ZL112 Valve option now available (ZL112 only)

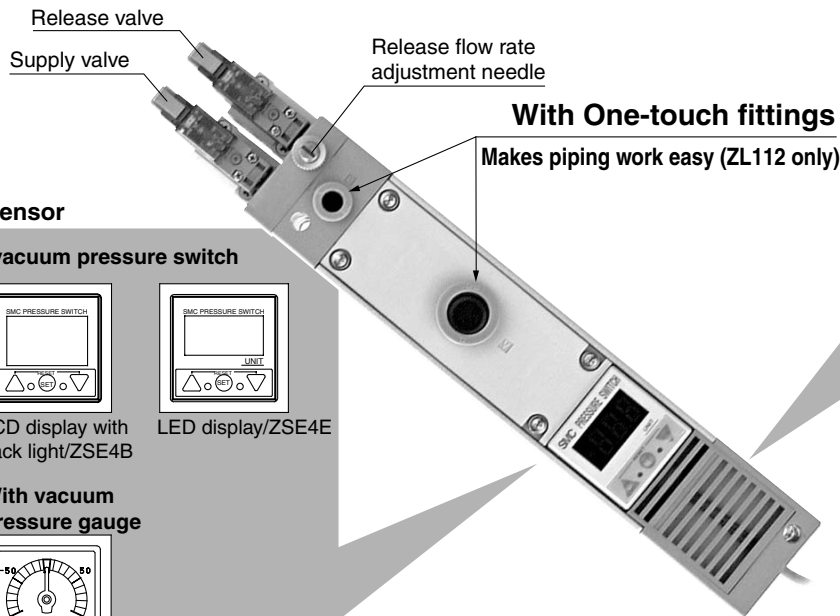

### Vacuum pressure sensor

#### With digital vacuum pressure switch

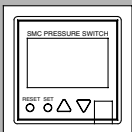

LCD display/ZSE4

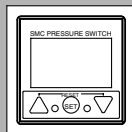

LCD display with back light/ZSE4B

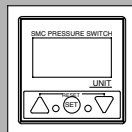

LED display/ZSE4E

#### With adaptor for vacuum

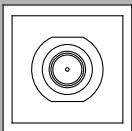

#### With vacuum pressure gauge

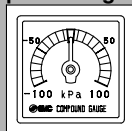

## Series Variations

Series	Maximum suction flow rate (ℓ/min (ANR))	Air consumption (ℓ/min (ANR))	Vacuum pressure sensor option								
			Exhaust port		With valve		With digital vacuum pressure switch			Vacuum pressure gauge	Vacuum adaptor
			Built-in silencer	Port exhaust	With supply and release valves	With supply valve	ZSE4E	ZSE4B	ZSE4		
ZL112	100	63	●	●	●	●	●	●	●	●	●
ZL212	200	126	●	●	●	●	●	●	●	●	●

- ZX
- ZR
- ZM
- ZH
- ZU
- ZL
- ZY
- ZQ
- ZF
- ZP
- ZCU
- AMJ
- Misc.

## Precautions

Be sure to read before handling. Refer to pages 13-15-3 to 13-15-4 for Safety Instructions and Common Precautions on the products mentioned in this catalog, and refer to page 13-1-5 for Precautions on every series.

### Piping

#### Caution

1. Connect the compressed air supply piping separately to the solenoid valves and ejector valves. Also, connect each ejector valve to separate piping system.

### Operation of Ejector Valves

#### Caution

1. When the pilot valve for air supply is turned ON, the main valve switches, and vacuum is generated by the flow of compressed air from the nozzle to the diffuser. When the pilot valve for vacuum release is turned ON, the main valve switches, and the vacuum is quickly released as air passes through the release flow adjustment needle and flows to the vacuum port.

### Operating Environment

#### Caution

1. Avoid use exposed to direct sunlight.

### Solenoid Valves (Series ZL112/ZL212)

#### Caution

1. For specific product precautions on solenoid valves (Series ZL112), refer to the solenoid valve (Series SYJ500) catalog.

## ⚠ Precautions

Be sure to read before handling. Refer to pages 13-15-3 to 13-15-4 for Safety Instructions and Common Precautions on the products mentioned in this catalog, and refer to page 13-1-5 for Precautions on every series.

### Selection

#### ZL112

##### Exhaust Characteristics

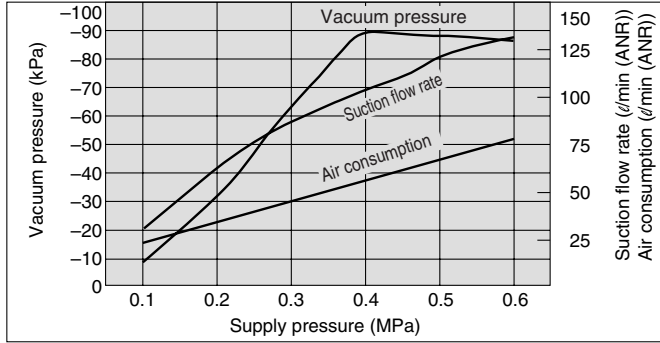

##### Flow Characteristics

Supply pressure: 0.4 MPa

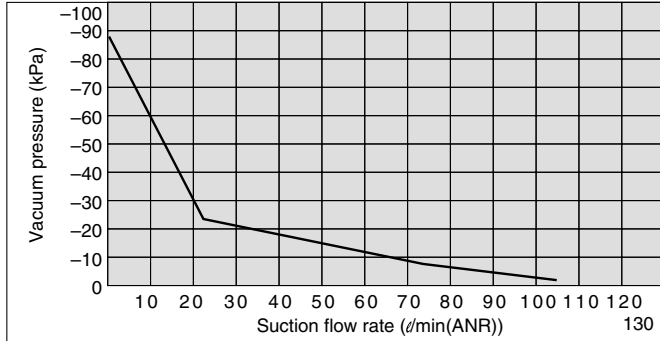

##### Time to Reach Vacuum

Tank capacity: 1ℓ  
Supply pressure: 0.4 MPa

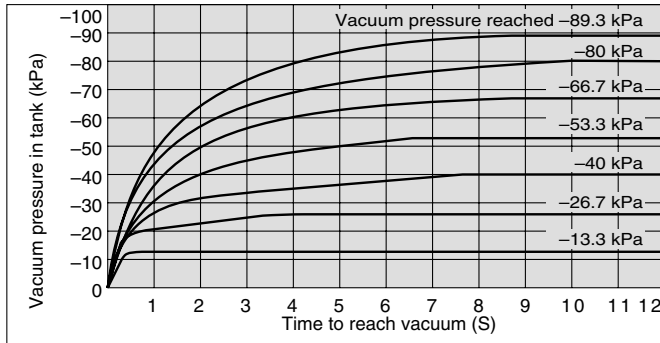

##### <How to Read the Graph>

The graphics indicate the time required to reach a vacuum pressure determined by adsorption conditions for workpieces, etc., starting from atmospheric pressure in a 1ℓ sealed tank. Approximately 8.8 seconds are necessary to attain a vacuum pressure of -89.3 kPa.

#### ZL212

##### Exhaust Characteristics

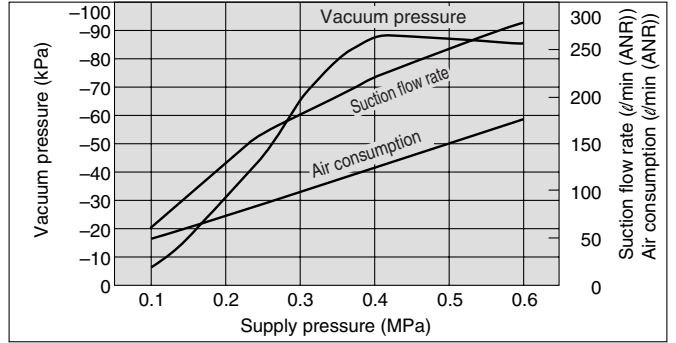

##### Flow Characteristics

Supply pressure: 0.4 MPa

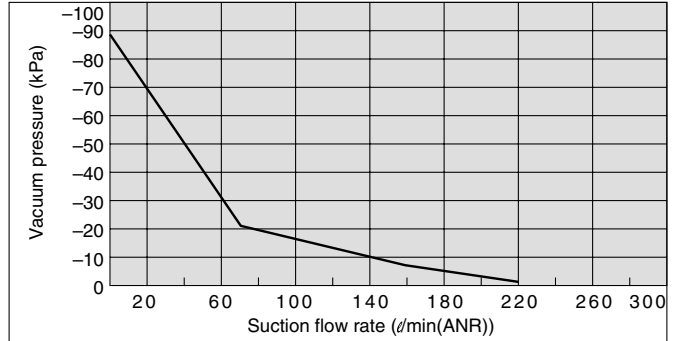

##### Time to Reach Vacuum

Tank capacity: 1ℓ  
Supply pressure: 0.4 MPa

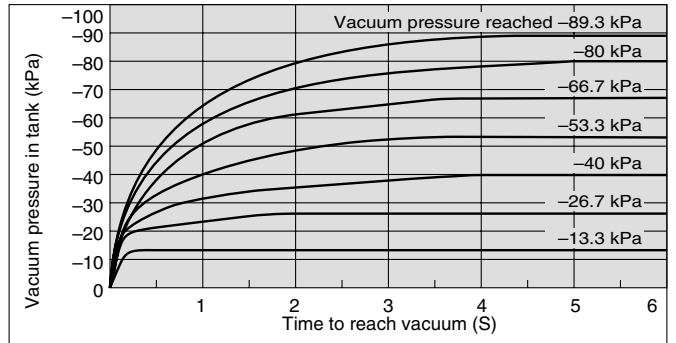

##### <How to Read the Graph>

The flow characteristics indicate the relationship between the vacuum pressure and the suction flow rate of the ejector, and show that when the suction flow rate changes the vacuum pressure also changes. In general, this indicates the relationship at the ejector's standard operating pressure. In the graph, Pmax indicates the maximum vacuum pressure, and Qmax indicates the maximum suction flow rate. These are the values that are published as specifications in catalogs, etc. Changes in vacuum pressure are explained below.

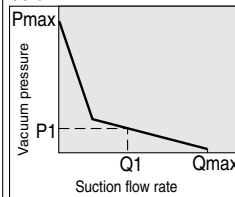

1. If the ejector's suction port is closed and sealed tight, the suction flow rate becomes "0" and the vacuum pressure increases to the maximum (Pmax).
2. If the suction port is opened and air is allowed to flow (the air leaks), the suction flow rate increases and the vacuum pressure decreases. (the condition of P1 and Q1)
3. If the suction port is opened completely, the suction flow rate increases to the maximum (Qmax), while the vacuum pressure then drops almost to "0" (atmospheric pressure). When adsorbing work pieces which are permeable or subject to leakage, etc., caution is required as the vacuum pressure will not be very high.

- ZX
- ZR
- ZM
- ZH
- ZU
- ZL
- ZY
- ZQ
- ZF
- ZP
- ZCU
- AMJ
- Misc.

# Multistage Ejector

## Series ZL112

### How to Order

Without valve

**ZL1 12**

With valve

**ZL1 12**
**K1 5 M Z**
**E 25**
**Nozzle diameter**

12	1.2 mm
----	--------

**Exhaust type**

Nil	Built-in silencer
P	Port exhaust

**Exhaust port thread type  
(Port exhaust only)**

Nil	Rc 1/2
F	G 1/2
N	1/2-14 NPT
T	1/2-14 NPTF

**Supply valve/Release valve combination**

K1	With supply and release valves
K2	With supply valve

**Rated voltage**

DC specifications	
5	24 V
6	12 V
V	6 V
S	5 V
R	3 V
AC specifications (50/60 Hz)	
1	100 V
2	200 V
3	110 V [115 V]
4	220 V [230 V]

**Electrical entry**

G		Lead wire length 0.3 m
H	Grommet	Lead wire length 0.6 m
L		Lead wire length 0.3 m
LN	L plug connector	Without lead wires
LO		Without connector
M		Lead wire length 0.3 m
MN	M plug connector	Without lead wires
MO		Without connector

**Lead wire length**

Nil	0.5 m
L	2.9 m

**Unit specifications**

Nil	With unit switching function <sup>(1)</sup>
M	SI unit only <sup>(2)</sup>

Note 1) W/ unit switching function is not permitted to sell for the domestic use in Japan, because the new Weight and Measure Act has been implemented since October '99.

Note 2) Fixed unit: kPa

**Digital vacuum pressure switch specifications**

For E (ZSE4) EB (ZSE4B)		
25	NPN output	Lead wire length 0.5 (2.9) m
26	Analog output	Lead wire length 0.5 (2.9) m
65	PNP output	Lead wire length 0.5 (2.9) m
For EE (ZSE4E)		
27	NPN output	Lead wire length 0.5 (2.9) m
26	Analog output	Lead wire length 0.5 (2.9) m
67	PNP output	Lead wire length 0.5 (2.9) m

\* Not required for Nil, vacuum adapter ("GN") and vacuum pressure gauge ("G").

**Vacuum pressure sensor**

Nil	None
GN	Vacuum adapter Rc 1/8
G	With vacuum pressure gauge
E	With digital vacuum pressure switch ZSE4
EB	With digital vacuum pressure switch ZSE4B
EE	With digital vacuum pressure switch ZSE4E

**Manual override**

Nil	Non-locking push type
D	Locking slotted type

**Light/Surge voltage suppressor**

Nil	Without light/surge voltage suppressor
S	With surge voltage suppressor
Z	With light/surge voltage suppressor
U	With light/surge voltage suppressor (Non-polar type)

\* Type U is 24 or 12 VDC only.

\* Since surge voltage is prevented by a rectifier in the case of AC, there is no type "S".

**Ejector Specifications****Standard****With valve****With vacuum pressure gauge****Adapter****Port exhaust**

Model	ZL112
Nozzle diameter	ø1.2 mm
Maximum suction flow rate	100 ℓ/min (ANR)
Air consumption	63 ℓ/min (ANR)
Maximum vacuum pressure	-84 kPa
Maximum operating pressure	0.7 MPa
Supply pressure range	0.2 to 0.5 MPa
Standard supply pressure	0.4 MPa
Operating temperature range	5 to 50°C

**Supply/Release Valve Specifications**

Part no.	SYJ514-□□□
Type of valve actuation	N.C.
Fluid	Air
Operating pressure range   Internal pilot type	0.2 to 0.5 MPa
Ambient and fluid temperature	5 to 50°C
Response time (For 0.5 MPa)	25 ms or less
Maximum operating frequency <sup>(1)</sup>	5 Hz
Manual override	Non-locking push type/Locking slotted type
Pilot exhaust type	Pilot valve individual exhaust, Main valve/Pilot valve common exhaust
Lubrication	Not required
Mounting position	Unrestricted
Impact/Vibration resistance	150/30 m/s <sup>2</sup>
Enclosure <sup>(2)</sup>	Dust proof

Note 1) Based on JIS B 8374-1981 dynamic performance test. (coil temperature 20°C, at rated voltage, without surge voltage suppressor)

Note 2) Impact resistance: No malfunction when tested with a drop tester in the axial direction and at a right angle to the main valve and armature, one time each in both energized and deenergized states. (initial value)

Vibration resistance: No malfunction when tested with one sweep of 45 to 2000 Hz in the axial direction and at a right angle to the main valve and armature, one time each in both energized and deenergized states. (initial value)

Note 3) Refer to "Best Pneumatics Vol. 4" for details on valves.

**Option Specifications****Vacuum Pressure Gauge Specifications**

Part no.	GZ30S
Fluid	Air
Pressure range	-100 to 100 kPa
Scale range (Angular)	230°
Accuracy	3% F.S. (Full span)
Class	Class 3
Operating temperature range	±0 to 50°C
Material	Housing: Polycarbonate/ABS resin

**JIS Symbol**

Standard

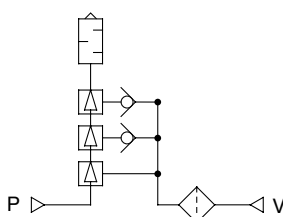

ZX

ZR

ZM

ZH

ZU

**ZL**

ZY

ZQ

ZF

ZP

ZCU

AMJ

Misc.

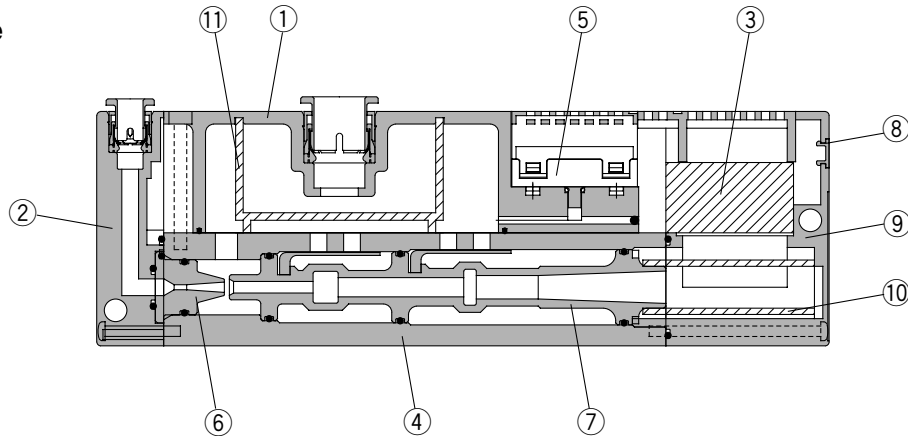
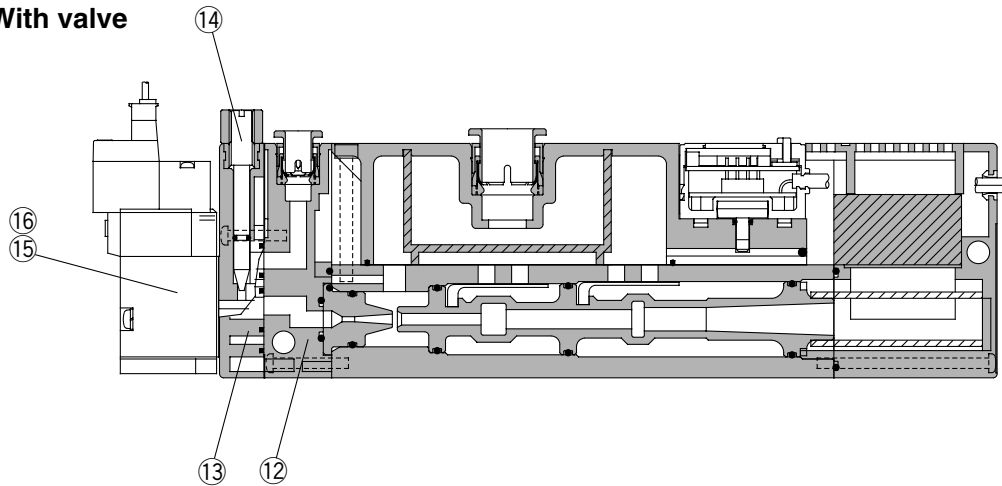

**Construction****Without valve****With valve**

ZX

ZR

ZM

ZH

ZU

**ZL**

ZY

ZQ

ZF

ZP

ZCU

AMJ

Misc.

**Component Parts**

No.	Description	Part no.	Note
①	Suction cover		
②	Front cover		Without valve
③	End cover		
④	Body		
⑤	Vacuum sensor unit		
⑥	Nozzle		
⑦	Diffuser		
⑧	Detent plug	P397110	Other than vacuum switch
	Lead wire cover	P397176	Vacuum switch specifications
⑫	Front cover B		With valve
⑬	Valve plate		With valve
⑭	Needle		With valve
⑮	Supply valve (N.C.)	SYJ514	With valve
⑯	Release valve (N.C.)	SYJ514	With valve

**Replacement Parts**

No.	Description	Material	Part no.
⑨	Sound absorbing material B	PVF	ZL112-SP01 (Set no. for 9, 10 & 11)
⑩	Sound absorbing material A	PVF	
⑪	Suction filter	PE	

\* When ordering a vacuum pressure gauge or a digital vacuum pressure switch separately, use the part numbers shown in the option specifications on page 13-7-5.

# Series ZL

## Dimensions: Series ZL112 (Without valve)

**Standard  
ZL112**

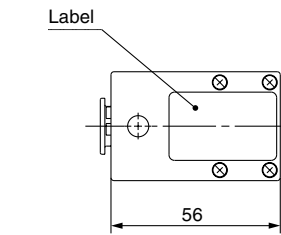
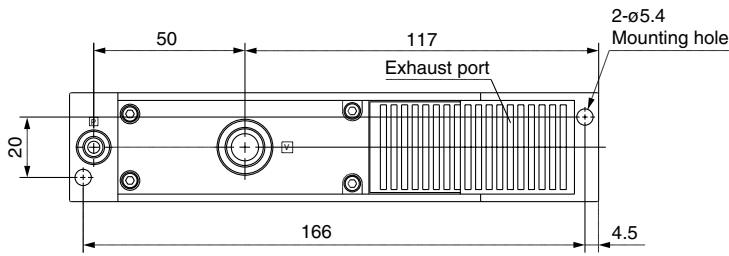

**Port exhaust  
ZL112P**

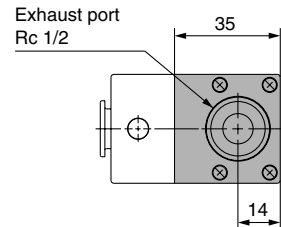
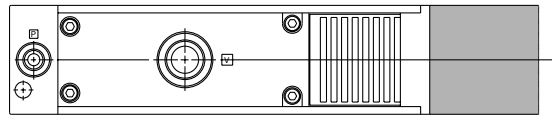

**With vacuum pressure gauge  
ZL112-G**

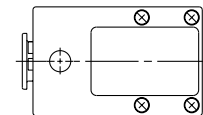
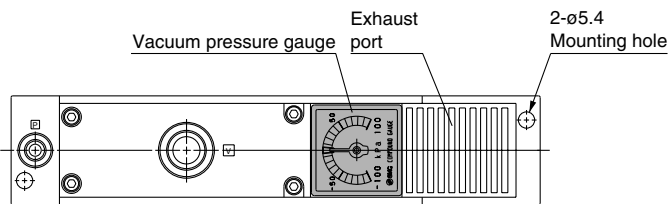

**With vacuum adapter  
ZL112-GN**

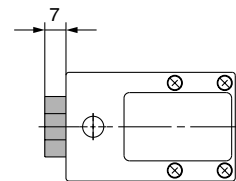
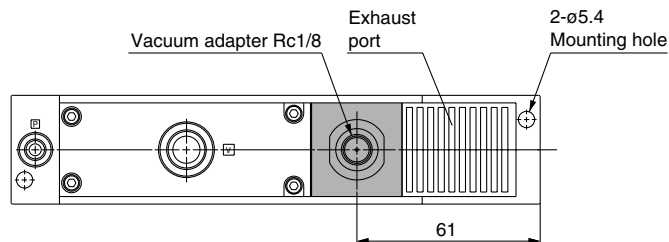

**With digital vacuum pressure switch  
ZL112-E**

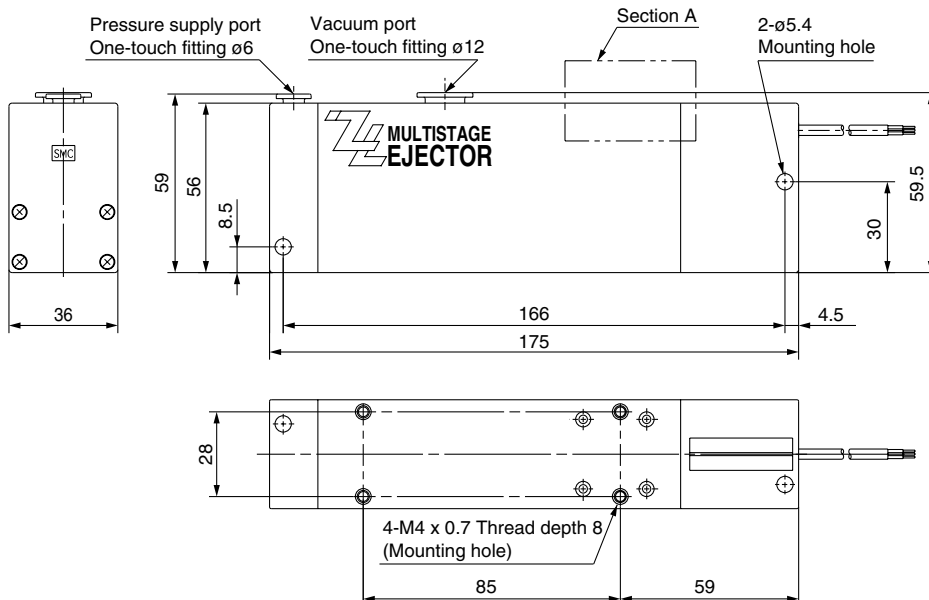
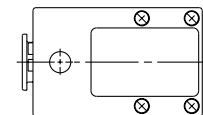
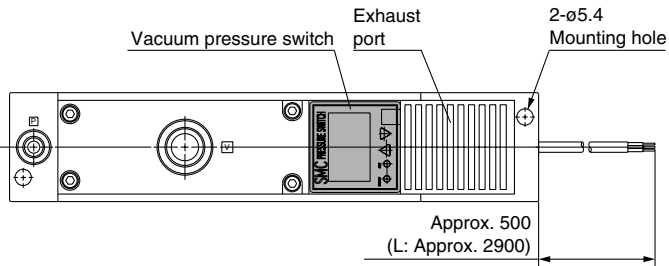

**Section A/  
With Digital Vacuum Pressure Switch**

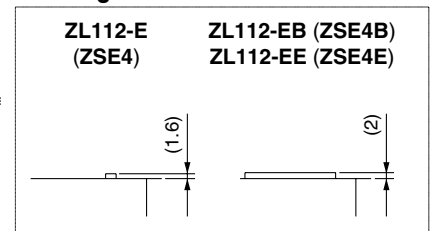

**Dimensions: Series ZL112 (With Valve)**

With supply valve and release valve  
**ZL112-K1□L□□-E25(L)-M**

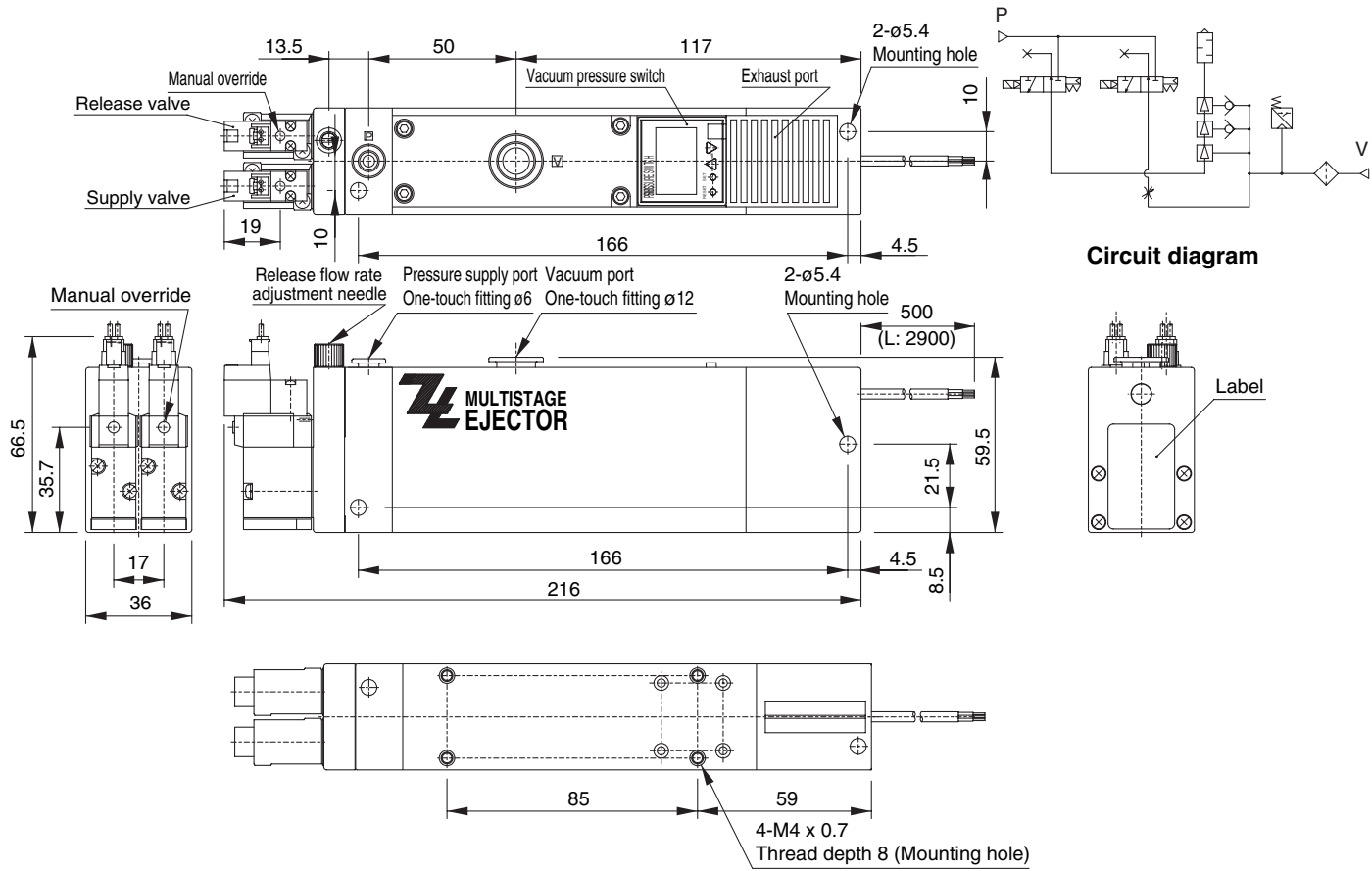

With supply valve  
**ZL112-K2□L□□-E25(L)-M**

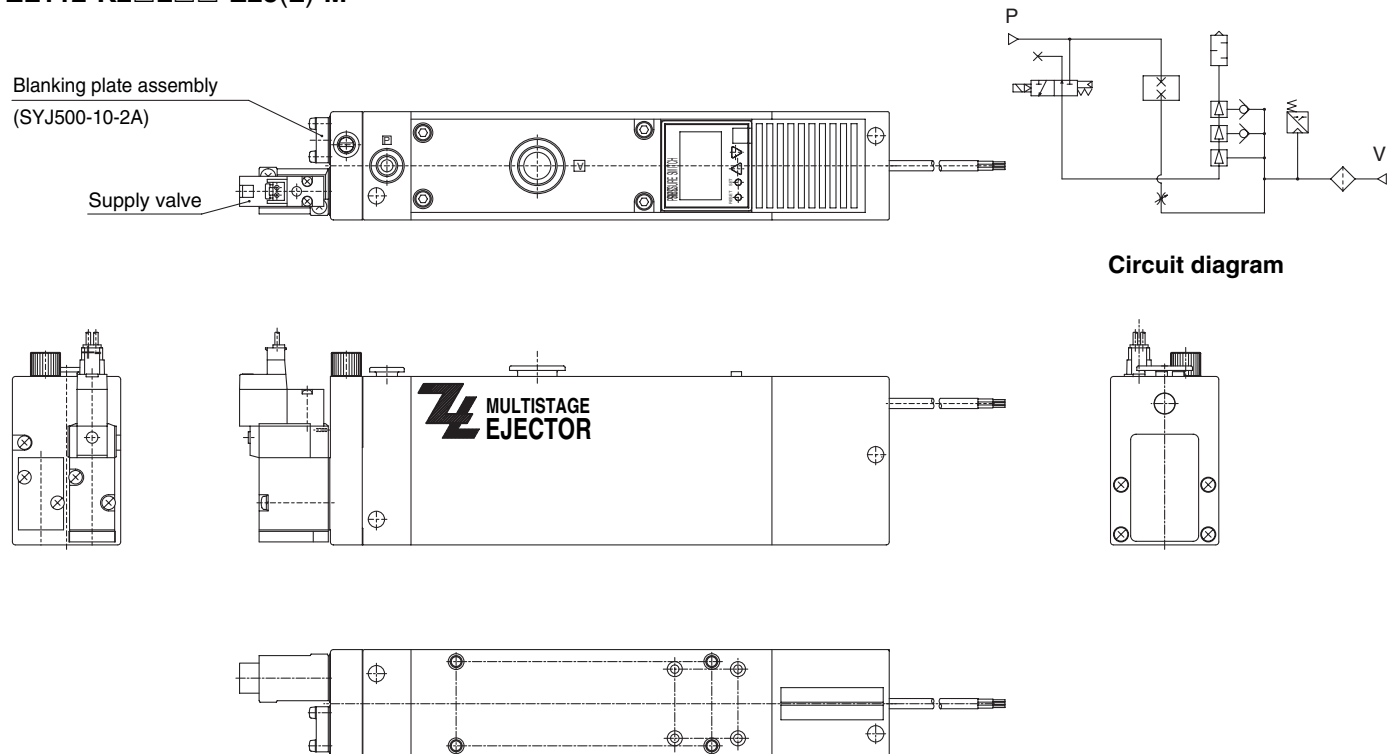

# Multistage Ejector

## Series ZL212

Standard



With vacuum pressure gauge



With digital vacuum pressure switch



With adaptor



Port exhaust



### How to Order

ZL2 12

Nozzle diameter  
12 1.2 mm

Exhaust specifications  
Nil Built-in silencer  
P Port exhaust

Vacuum pressure sensor

Nil	None
GN	Adaptor Rc 1/8
G	With vacuum pressure gauge
E	With digital vacuum pressure switch ZSE4
EB	With digital vacuum pressure switch ZSE4B
EE	With digital vacuum pressure switch ZSE4E

Lead wire length

Nil	0.5 m
L	2.9 m

Unit specifications

Nil	With unit switching function <sup>(1)</sup>
M	SI unit only <sup>(2)</sup>

Note 1) W/ unit switching function is not permitted to sell for the domestic use in Japan, because the new Weight and Measure Act has been implemented since October '99.

Note 2) Fixed unit: kPa

Digital vacuum pressure switch specifications

For E (ZSE4) EB (ZSE4B)		
25	NPN output	Lead wire length 0.6 (3.0) m
26	Analog output	Lead wire length 0.6 (3.0) m
65	PNP output	Lead wire length 0.6 (3.0) m
For EE (ZSE4E)		
27	NPN output	Lead wire length 0.6 (3.0) m
26	Analog output	Lead wire length 0.6 (3.0) m
67	PNP output	Lead wire length 0.6 (3.0) m

\* Not required for Nil, vacuum adaptor ("GN") and vacuum pressure gauge ("G").

### Ejector Specifications

Model	ZL212
Nozzle diameter	ø1.2 mm x 2
Maximum suction flow rate	200 ℓ/min (ANR)
Air consumption	126 ℓ/min (ANR)
Maximum vacuum pressure	-84 kPa
Maximum operating pressure	0.7 MPa
Supply pressure range	0.2 to 0.5 MPa
Standard supply pressure	0.4 MPa
Operating temperature range	5 to 50°C

\* Refer to pages 13-7-4 to 13-7-5 for vacuum pressure gauge and digital vacuum pressure switch specifications.

JIS Symbol  
Standard

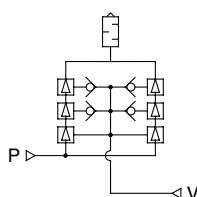

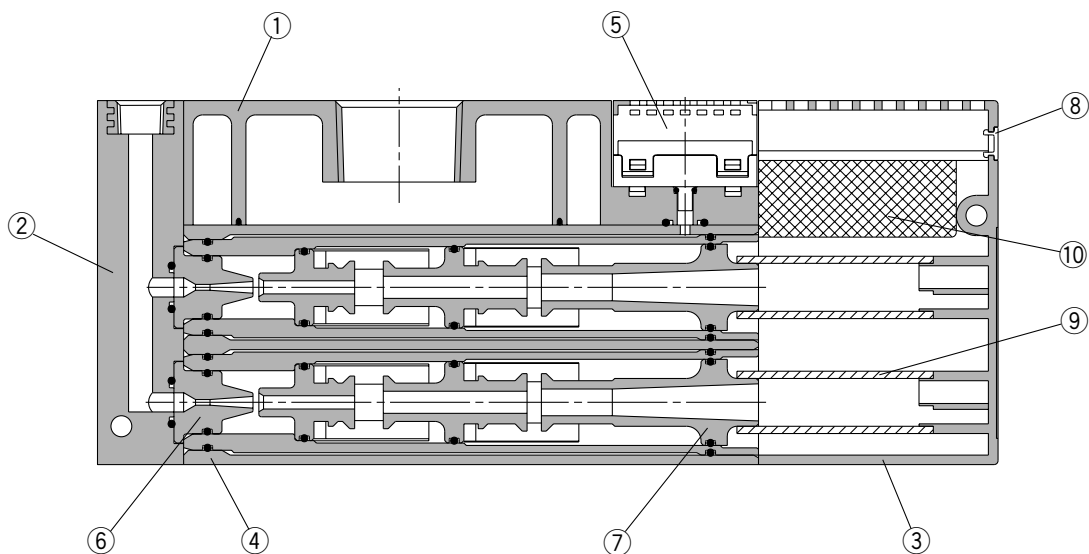
**Construction****Component Parts**

No.	Description	Part no.	Note
①	Suction cover		
②	Front cover A		
③	End plate		
④	Body		
⑤	Vacuum sensor unit		
⑥	Nozzle		
⑦	Diffuser		
⑧	Detent plug	P397110	Other than vacuum switch
	Lead wire cover	P397176	Vacuum switch specifications

**Replacement Parts**

No.	Description	Material	Part no.
⑨	Sound absorbing material A	PVF	P397114
⑩	Sound absorbing material	PVF	P397230

\* When ordering a vacuum pressure gauge or a digital vacuum pressure switch separately, use the part numbers shown in the option specifications on page 13-7-5.

ZX

ZR

ZM

ZH

ZU

**ZL**

ZY

ZQ

ZF

ZP

ZCU

AMJ

Misc.

# Series ZL

## Dimensions: Series ZL212

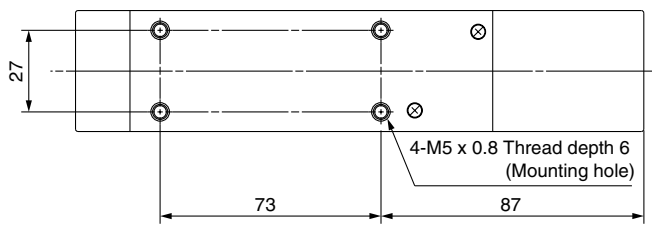
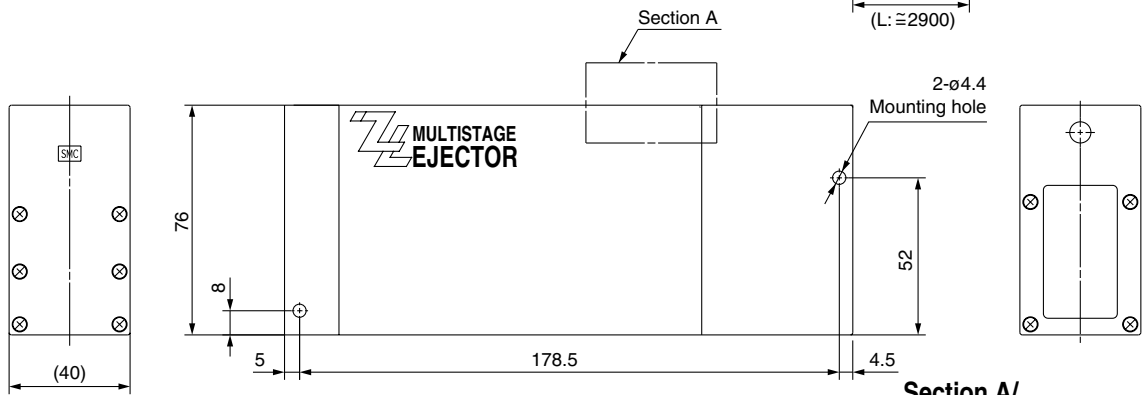
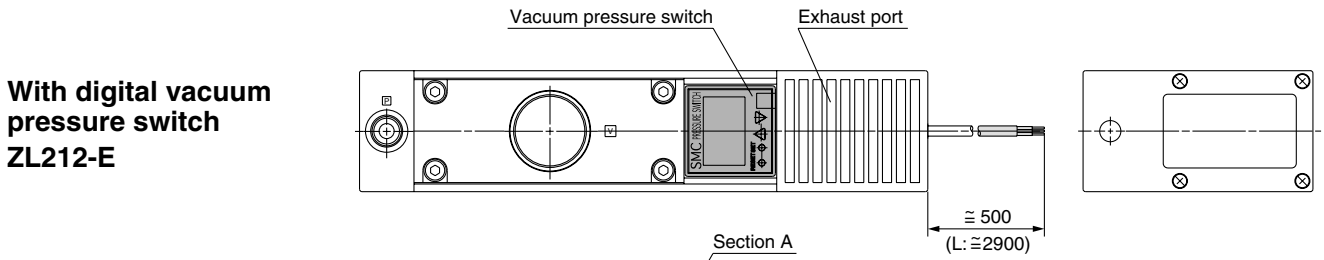
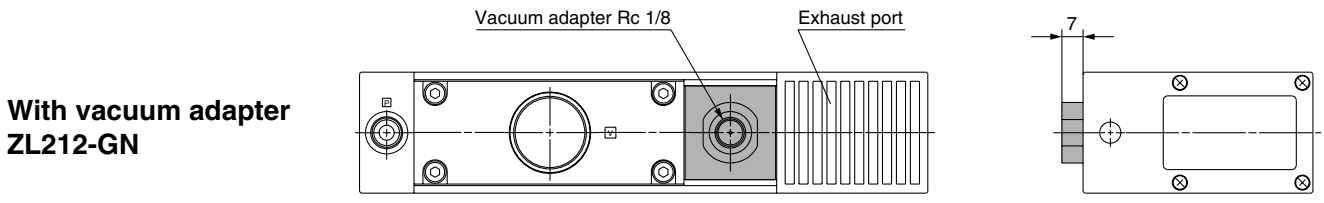
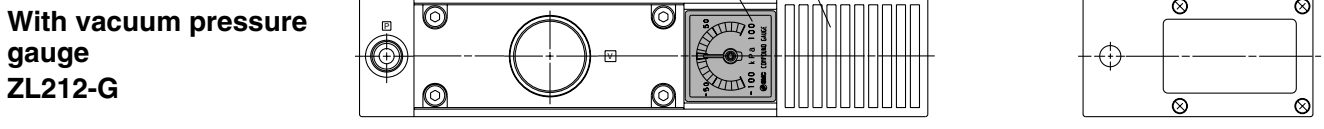
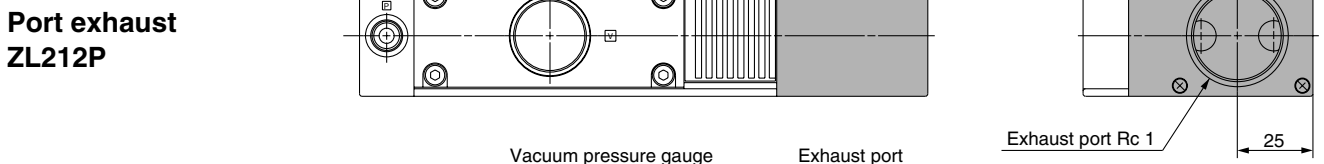
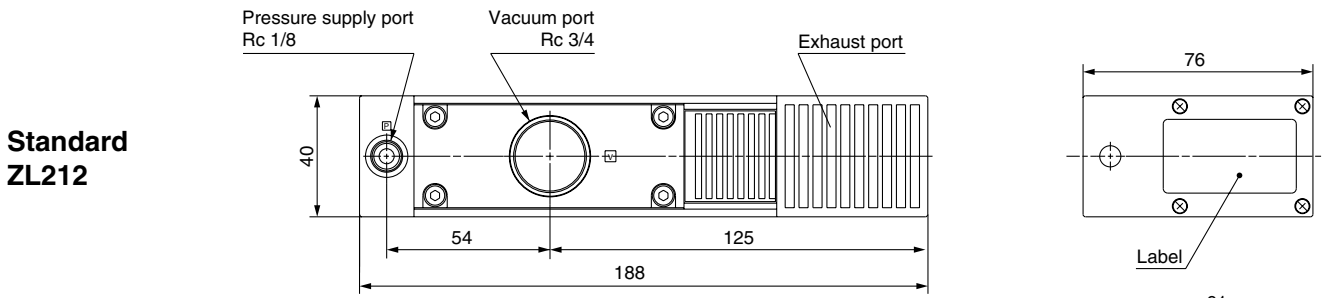

**Section A/  
With Digital Vacuum Pressure Switch**

