

Compact Pressure Switch

Series ZSE1/ISE1

For Vacuum

For Positive Pressure

For General Pneumatics



Can be integrated with ZM ejector system.

Variable hysteresis

1 to 10% of set pressure (Variable)

Easy and simple wiring

ZSE□
ISE□

PSE

ZSE₁SE₃

PS

ZSE₁₂

ZSP

ISA2

IS□

ZSM

PF2□

IF□

Data

Series ZSE1/ISE1

How to Order

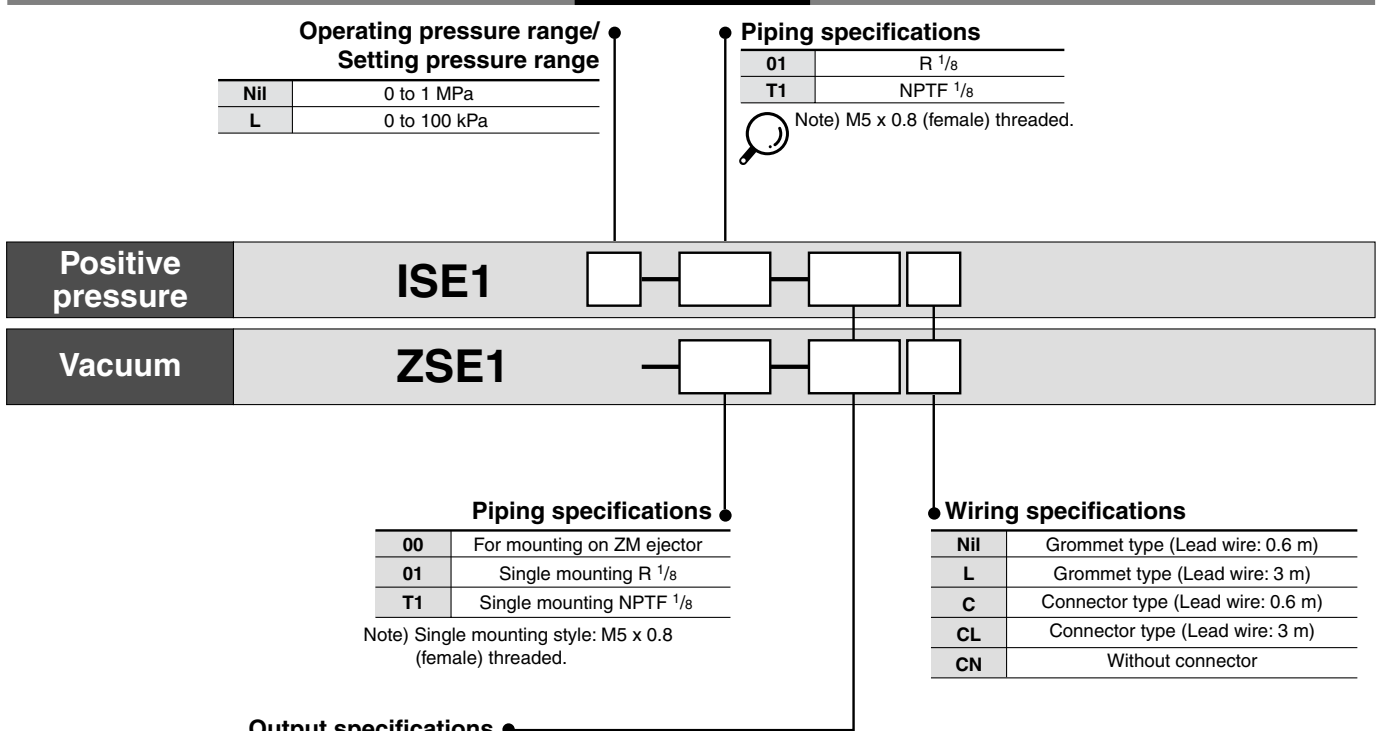

Output specifications

14	NPN open collector 1 output w/o analog output, 3 turns adjustment
15	NPN open collector 1 output w/o analog output, 200 degrees adjustment
16	NPN open collector 2 output w/o analog output, 3 turns adjustment
17	NPN open collector 2 output w/o analog output, 200 degrees adjustment
18	NPN open collector 1 output w/analog output, 3 turns adjustment
19	NPN open collector 1 output w/analog output, 200 degrees adjustment
55	PNP open collector 1 output w/o analog output, 200 degrees adjustment

With Connector/How to Order

- Without lead wire (Connector 1 pc., Socket 4 pcs.) ...**ZS-20-A**
- With lead wire.....**ZS-20-5A-**

Note) When ordering switch with 5 m long lead wire, indicate both part numbers.

Ex.) **ZSE1-01-15CN**.....1 pc.
ZS-20-5 A-50.....1 pc.

Lead wire length

Nil	0.6 m
30	3 m
50	5 m

Compact Pressure Switch Series ZSE1/ISE1

Specifications

		ZSE1	ISE1L	ISE1
		For vacuum	For low pressure	For high pressure
Operating pressure range/Regulating pressure range		0 to -101 kPa	0 to 100 kPa	0 to 1 MPa
Proof pressure		500 kPa		1.5 MPa
Fluid		Air/Non-corrosive, non-flammable gas		
Power supply voltage		12 to 24 VDC $\pm 10\%$, Ripple (P-P)10% or less		
Current consumption		1 output: 17 mA or less at 24 VDC, 2 output: 25 mA or less at 24 VDC		
Response time		5 ms or less		
Repeatability		$\pm 1\%$ F.S. or less		
Resistance	Enclosure	IP40		
	Operating temperature range	Operating: 0 to 60°C, Stored: -10 to 60°C (With no condensation)		
	Operating humidity range	Operating/Stored: 35 to 85%RH (With no condensation)		
	Vibration resistance	10 to 500 Hz at whichever is smaller of 1.5 mm amplitude or 98 m/s ² acceleration, in X, Y, Z directions for 2 hrs. each (De-energized)		
	Impact resistance	980 m/s ² in X, Y, Z directions, 3 times each (De-energized)		
Temperature characteristics (Based on 25°C)		$\pm 3\%$ F.S. or less		
Withstand voltage		1000 VAC for 1 min. (Between lead wires and case)		
Insulation resistance		50 M Ω or more (at 500 VDC by megameter)		
Port size		01: R 8, M5 x 0.8 T1: NPTF 1/8, M5 x 0.8 00: ZM ejector mount type		
Weight		Approx. 40 g (Including 0.6 m—Long lead wire)		

ZSE□
ISE□

PSE

ZSE3

PS

ZSE₂

ZSP

ISA2

IS□

ZSM

PF2□

IF□

Data

Output Specifications

Model	-14	-15	-16	-17	-18	-19	-55
Output type	NPN open collector 30 V, 80 mA						PNP open collector 80 mA
Residual voltage	1 V or less (With load current of 80 mA)						
Number of outputs	1		2		1		
Hysteresis	1 to 10% of set prss. (Variable)		3% F.S. or less (Fixed)		1 to 10% of set prss. (Variable)		1 to 10% of set prss. (Adjustable)
Indicator light	ON: when output is ON (Red)		ON: when output is ON (OUT1: Red, OUT2: Green)		ON: when output is ON (Red)		
Trimmer adjustment	3 turns	200 degrees	3 turns	200 degrees	3 turns	200 degrees	
Analog output	None				1 to 5 V $\pm 5\%$ F.S. Output impedance: Approx. 1 k Ω		None

Series ZSE1/ISE1

Calibration Procedure

- Set the ON-pressure by the pressure setting trimmer. Turning clockwise can set the high pressure/high vacuum pressure.
- In the event of setting, use a flat head screwdriver suited for the groove of a trimmer, and rotate it lightly with a fingertip.

1/2 ZSE1-□□-14/-15/-18/-19

- Switches with variable hysteresis can be adjusted by means of the HYS potentiometer in the range 1 to 10% of the setting pressure range.
- Readjust it when the hysteresis setting trimmer was changed after setting the ON pressure.

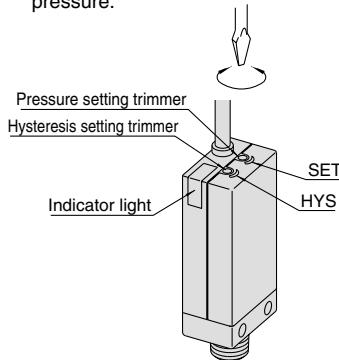

1/2 ZSE1(L)-□□-16/-17

- With pressure setting trimmer 1 (SET 1), OUT 1 (Black lead wire, Red LED) can be set.
- With pressure setting trimmer 2 (SET 2), OUT 2 (White lead wire, Green LED) can be set.

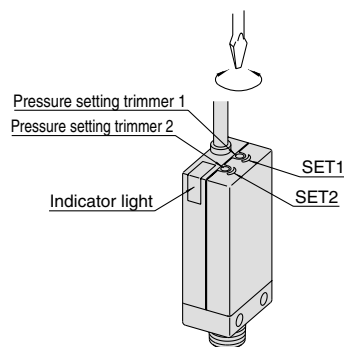

- Set the possible min. pressure for adsorption confirmation. If setting the pressure lower than that, switch becomes ON in case that adsorption is not completely done. If setting the pressure higher than that, switch does not become ON even though it may adsorb workpieces.

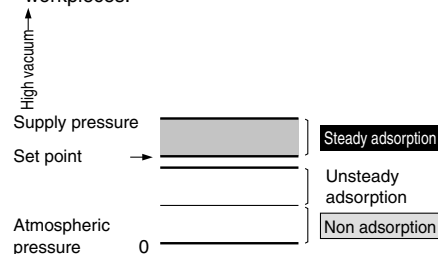

• Regarding the pressure setting

⚠ Caution

Observe the following precautions for setting the vacuum pressure:
Use your fingertips to gently turn the screwdriver.
Do not use a screwdriver with a large grip or with a tip that does not fit into the trimmer groove because this could strip the groove.

Hysteresis

Hysteresis is the pressure difference between the ON and the OFF pressure of the output signal. The set pressure is the pressure selected to switch from OFF to ON condition.

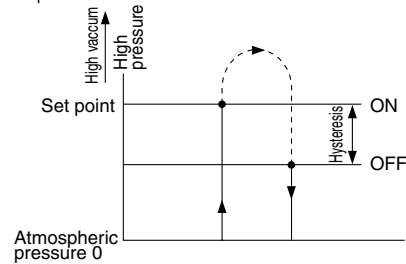

How to Use Connector

1. Attaching and detaching connectors

- When assembling the connector to the switch housing, push the connector straight onto the pins until the lever locks into the housing slot.
- When removing the connector from the switch housing, push the lever down to unlock it from the slot and then withdraw the connector straight off of the pin.

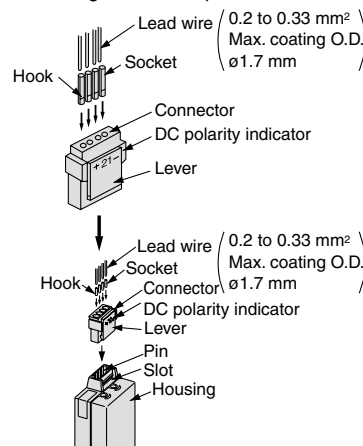

2. Crimping of lead wires and sockets

Strip 3.2 to 3.7 mm at the end of the lead wires, insert the ends of the core wires evenly into the sockets, and then crimp with a crimping tool. When this is done, take care that the coverings of the lead wires do not enter the core wire crimping area.
(Crimping tool: model no. DXT170-75-1)

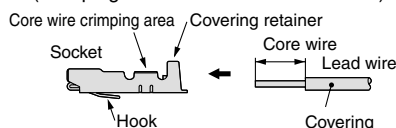

3. Attaching and detaching lead wires with sockets

- **Attaching**
Insert the sockets into the square holes of the connector (with +, 1, 2, - indication), and continue to push the sockets all the way in until they lock by hooking into the seats in the connector. (When they are pushed in their hooks open and they are locked automatically.) Then confirm that they are locked by pulling lightly on the lead wires.
- **Detaching**
To detach a socket from a connector, pull out the lead wire while pressing the socket's hook with a stick having a thin tip (about 1 mm). If the socket will be used again, first spread the hook outward.

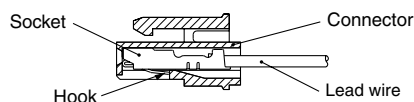

Internal Circuit and Wiring Example

1/2 ZSE1(L)-□□-14/-15

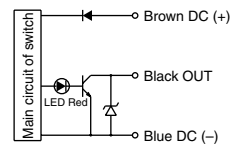

1/2 ZSE1(L)-□□-16/-17

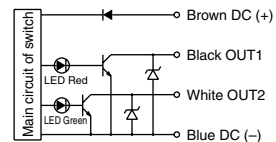

1/2 ZSE1(L)-□□-18/-19

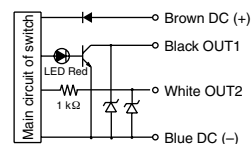

1/2 ZSE1(L)-□□-55

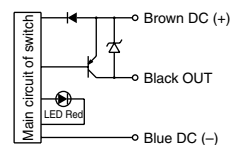

⚠ Caution

Refer to pages 16-14-3 to 16-14-4 for Safety Instructions and Common Precautions on the products mentioned in this catalog, and refer to pages 16-1-11 to 16-1-13 for Precautions on every series.

Compact Pressure Switch Series ZSE1/ISE1

Dimensions

Grommet type:
ZSE1-00-14/-15/-18/-19

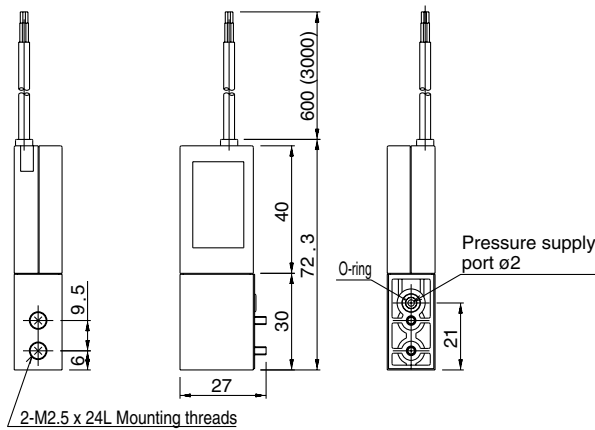
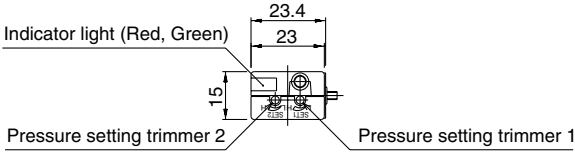
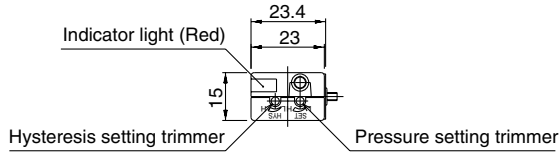

Connector type:
ZSE1-00-14C/-15C/-18C/-19C

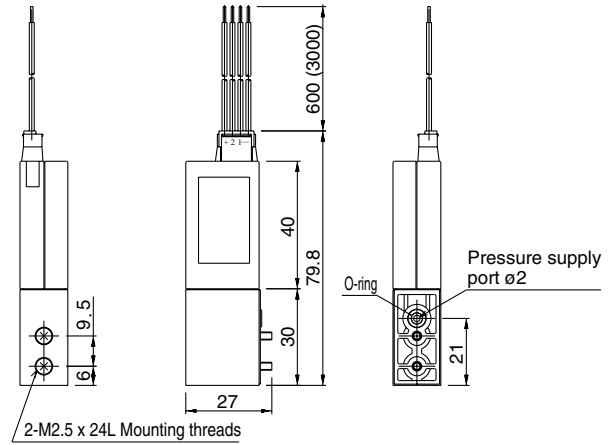
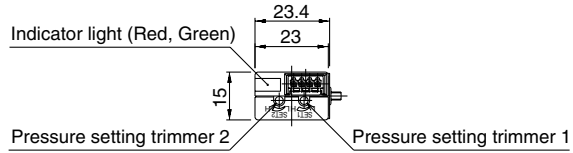
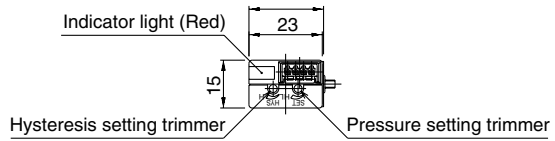

- ZSE
- ISE
- PSE
- $\frac{1}{2}$ SE3
- PS
- $\frac{1}{2}$ SE₁₂
- ZSP
- ISA2
- IS
- ZSM
- PF2
- IF
- Data

Grommet type:
 $\frac{1}{2}$ SE1-01_{T1}-14/-15/-18/-19

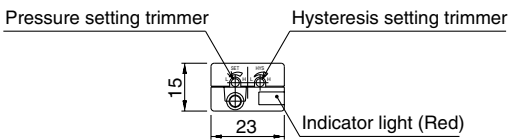

Connector type:
 $\frac{1}{2}$ SE1-01_{T1}-14C/-15C/-18C/-19C

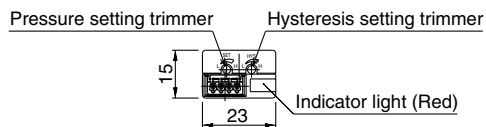

$\frac{1}{2}$ SE1-01-16/-17

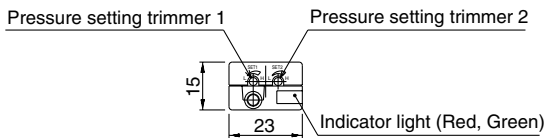

$\frac{1}{2}$ SE1-01-16C/-17C

