

Mechanical Style Pressure Switch

Series IS1000

Long service life:
5 million cycles



IS1000-01 IS1000-01-X202

Specifications

Model	IS1000-01
Fluid	Air/Inert gas
Proof pressure	1.0 MPa
Max. operating pressure	0.7 MPa
Regulating pressure range (at OFF point)	0.1 to 0.4 MPa
Hysteresis	0.08 MPa or less
Error of scale	±0.05 MPa
Repeatability	±0.05 MPa
Contacts	1a
Wiring specifications	Grommet, Lead wire length 0.5 m (Standard)
Fluid	Air
Ambient and fluid temperature	-5 to 60°C (No freezing)
Port size	R 1/8
Weight	74 g

ZSE
ISE

PSE

ZSE3

PS

ZSE1

ZSP

ISA2

IS

ZSM

PF2

IF

Data

Switch Characteristics

Max. contact capacity	AC 2 VA, 2 W DC		
Voltage	24 VAC/DC or less	48 VAC/DC	100 VAC/DC
Max. operating current	50 mA	40 mA	20 mA
Impact resistance	30 G		

Electrical Circuit

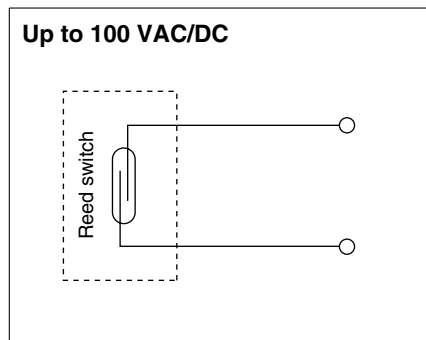

Operating Pressure Range

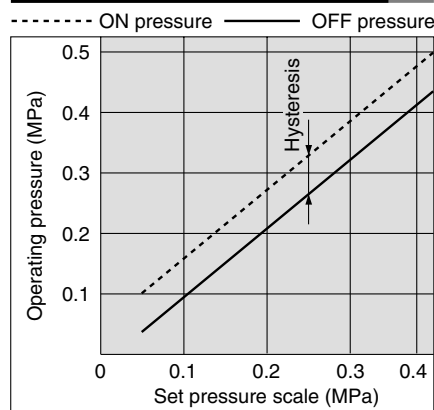

How to Order

IS1000 — 01 S —

Port size	
01	R 1/8
N01	NPT 1/8

Seal	
Nil	None
S	With seal

Option	
X201	Lead wire length 3 m
X202	Regulating pressure range 0.1 to 0.6 MPa
X215	Lead wire length 3 m Regulating pressure range 0.1 to 0.6 MPa

Series IS1000

Construction

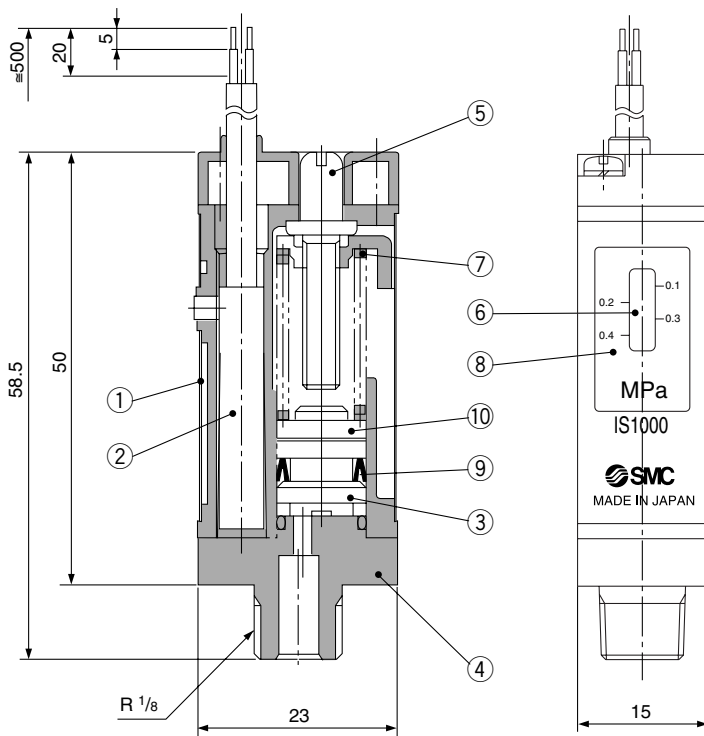

Component Parts

No.	Description	Material
①	Shield plate	Rolled steel plate
②	Switch assembly	—
③	Piston	Polyacetal
④	PT fittings	Zinc die-casted
⑤	Adjusting screw	Brass
⑥	Pointer	Brass
⑦	Spring	Stainless steel 304-WPB
⑧	Scale plate	Rigid vinyl chloride
⑨	Miniseal Y type	NBR
⑩	Magnet	Rare earth magnet

⚠ Precautions

Be sure to read before handling. Refer to pages 16-14-3 and 16-14-4 for Safety Instructions and Common Precautions on the products mentioned in this catalog, and refer to pages 16-1-11 to 16-1-13 for Precautions on every series.

Wiring

⚠ Warning

1. Connect load before connecting with power source.
2. In the case of induction load or lead wire exceeding 5 m long, the following contact protection box should be used. It may lead to damage to a switch.

Part no.	Voltage	Lead wire length
CD-P11	100 VAC	Switch side: 0.5 m
CD-P12	24 VDC	Load side: 0.5 m

3. Internal circuit of contact protection box

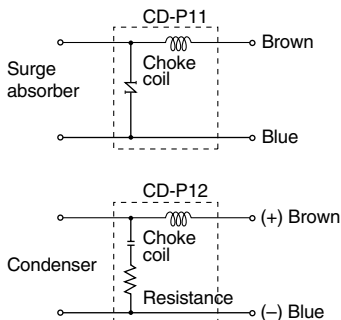

4. How to connect contact protection box

Connect the lead wires from the body and the contact protective box side indicated "SWITCH". Lead wire should be as short as possible, within 1 m.

5. Dimensions of lead wire

Enclosure: ϕ 3.4
Insulator: ϕ 1.1
Conductor: ϕ 0.64

Mounting/Piping

⚠ Warning

1. **When changing piping by hand, hold body.** Electrical wire must not be subjected to excessive force. It may cause a malfunction or damage.
2. **Do not drop nor apply excessive force.** It may cause a malfunction or damage.
3. **Tighten IS1000-01 applying the spanner on the PT fitting part.**

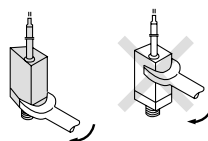

4. **Mounting direction is available in either horizontal or perpendicular.**

Pressure Source

⚠ Warning

1. Do not use with corrosive gases or fluids.
2. Never use in an environment where flammable fluid or gas is used. Since this is not an explosion-proof construction, it may lead to an explosive disaster.
3. Avoid use in vacuum applications. Switch may be imploded.

Pressure Setting

⚠ Warning

1. Scale of switching set display is the set value at the pressure drop.
2. When detecting ON-pressure signal, note that set pressure on scale plate plus ON-OFF differential (Hysteresis) will be ON-pressure signal.
3. Pressure display on the scale plate is just as a reference guide. For an accurate setting, measure it by pressure gauge.

Operating Environment

⚠ Warning

1. Avoid using a switch in a magnetic environment. It may cause a malfunction.
2. Do not use in such an environment, where water or oil is splashed. Since it is the open type construction, if water or oil make an ingress into the internal parts, the electric circuit will be corroded and may result in a malfunction or damage.
3. Avoid vibration. Vibration may cause malfunction or may cause setting to be incorrect.