



Series LC6D

Series LC6C

Series LX Dedicated Stepper Motor Driver and Positioning Driver

Series LC6D/LC6C

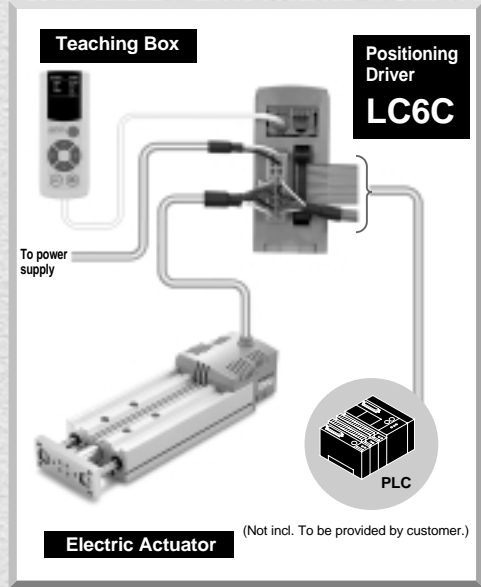
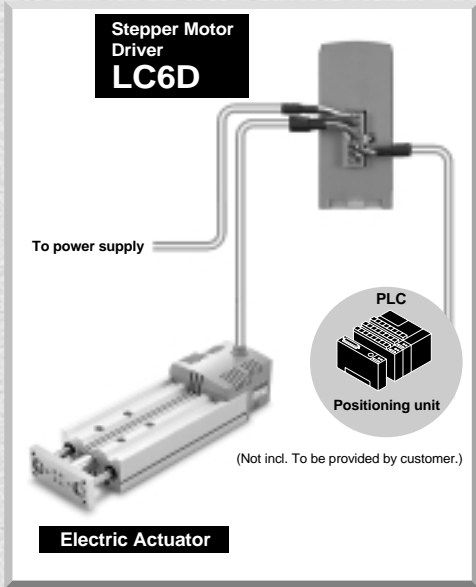

- Stepper Motor Driver/LC6D _____ Page 306
- Positioning Driver/LC6C _____ 309
- LC6C dedicated teaching box _____ 313
- Options _____ 315

LJ1

LG1

LC1

LX

LC6D/LC6C

Switches

Stepper Motor Driver

Series LC6D Series LX Dedicated



- Can be mounted on a DIN rail
- Driver position controlled by pulse signal
- Can be controlled by a general positioning unit or controller

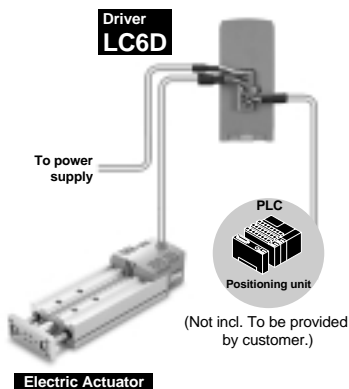

How to Order

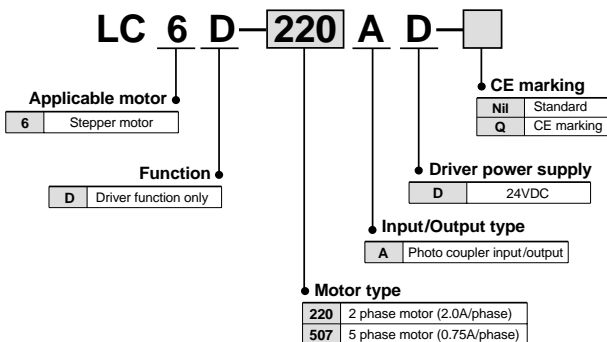

Applicable Actuators

Driver model	Applicable actuator	Motor type
LC6D-220AD	Guide rod type	LXPB2
	High rigidity slide table type	LXSH2
LC6D-507AD	Low profile slide table type	LXFH5
	High rigidity slide table type	LXSH5
	Guide rod type	LXPB5

Specifications

Part no.	LC6D-220AD	LC6D-507AD
Power supply	24VDC \pm 10%, 3A	24VDC \pm 10%, 2.5A
energization (Step angle °)	Full step (1.8°) Half step (0.9°)	Full step (0.72°) Half step (0.36°)
Motor current	2.0A/phase	0.75A/phase
Input signal	Photo coupler input (Input impedance 330 Ω)	
Maximum input frequency (See caution below.)	10kHz for full step 20kHz for half step	
Function	Auto current down, Power down input	
Connection method	Connector	
Operating environment	5° to 40°C	
	35 to 85% (with no condensation)	
Accessories	Connectors (receptacle, female terminal) Cable should be arranged by customer.	

CE marking

1. The combination of Series LC6D and Series LX has been certified for CE marking.

When using Series LX with CE marking, use it in combination with Series LC6D with CE marking.

2. The combination of Series LC6D and Series LX has been certified for EMC conformity.

EMC changes depending on the customer's control panel configuration, and the relationship between other electrical equipment and wiring. Therefore, conformity cannot be certified for the customer's equipment in the actual operating environment. As a result, it is necessary for the customer to verify final EMC conformity for the machinery and equipment as a whole.

Caution

Maximum speeds of actuators vary depending on the type. Observe the maximum speed of the actuator in use.

Pulse Signals

LC6D positioning is controlled by the number of pulse signal inputs to the CW and CCW terminals, and speed is controlled by pulse frequencies.

- Calculation for speed and pulse frequencies
Pulse frequency [pps] = (Speed [mm/s]/Lead [mm]) x Divisions per rotation
- Calculation for moving distance and pulse numbers
Pulse numbers = (Moving distance [mm]/Lead [mm]) x Divisions per rotation
- The divisions per rotation are as shown in the table below.

Driver	Energization type	Divisions per rotation
LC6D-220AD-□	Full step	200
	Half step	400
LC6D-507AD-□	Full step	500
	Half step	1000

Dimensions

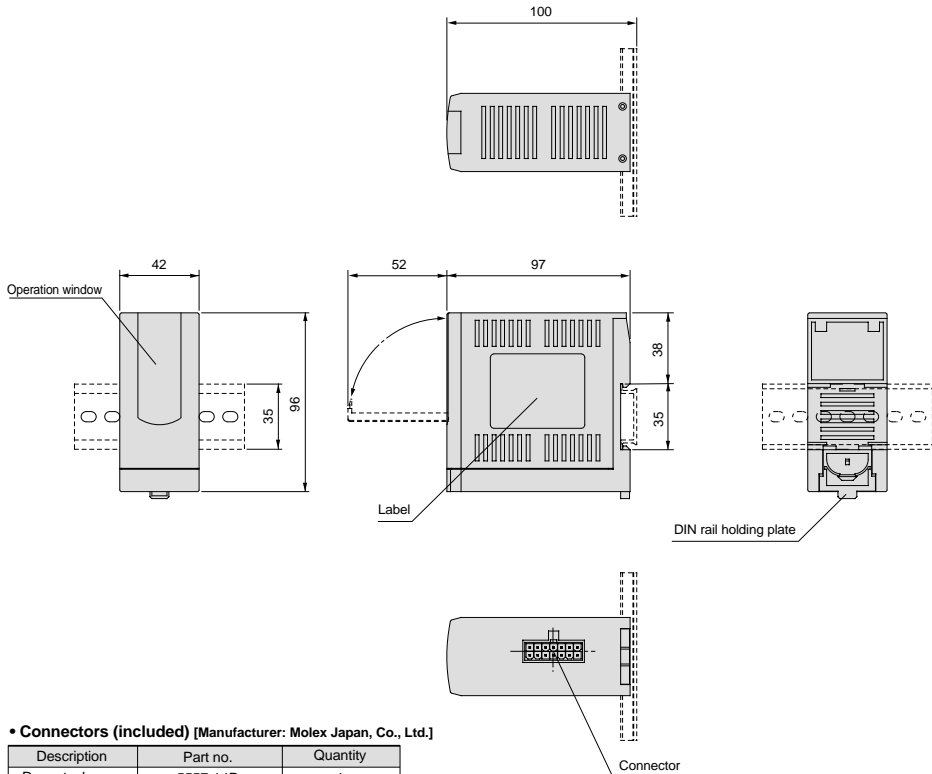

• Connectors (included) [Manufacturer: Molex Japan, Co., Ltd.]

Description	Part no.	Quantity
Receptacle	5557-14R	1
Female terminal	5556PBTL	14

• Wiring tools [Manufacturer: Molex Japan Co., Ltd.]

Wiring tools should be arranged by the customer.

Description	Part no.
Crimping tool	57026-5000 (for UL1007) 57027-5000 (for UL1015)
Puller	57031-6000

Series LC6D

Connection Examples

• Electrical wires

—— 0.5mm² or larger (AWG18 to 20)
 —— 0.2mm² or larger (shielding wire) (AWG18 to 24)

For open collector output

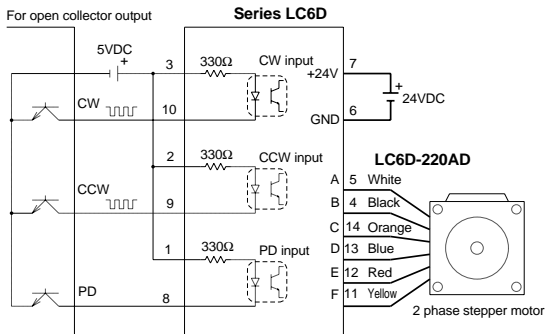

• Wiring numbers

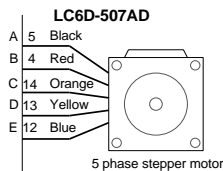
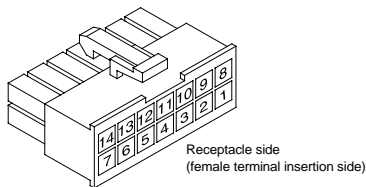

For line driver output

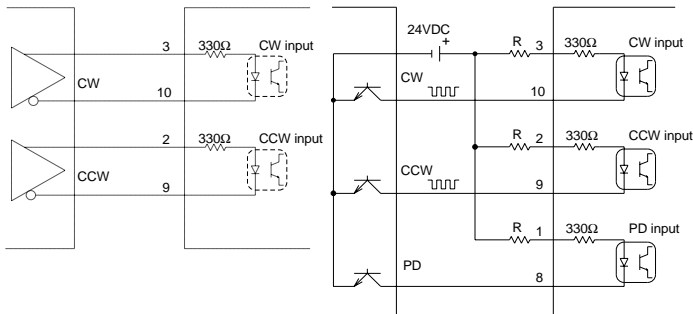

For a signal power supply of 24VDC, connect an external resistor R (1.3kΩ 1/2W) in order to hold the current to 15mA or lower.

Signal description	Function	Pin no.
+24V	Driver power supply +24V	7
GND	Driver power supply GND	6
CW+	CW pulse input terminal (+)	3
CW-	CW pulse input terminal (-)	10
CCW+	CCW pulse input terminal (+)	2
CCW-	CCW pulse input terminal (-)	9
PD+	Power down input terminal (+)	1
PD-	Power down input terminal (-)	8
A	Motor drive output A	5
B	Motor drive output B	4
C	Motor drive output C	14
D	Motor drive output D	13
E	Motor drive output E	12
F	Motor drive output F (LC6D-2□□□□ only)	11

Functions

• Function change-over switch

Use the function change-over switch to set each function. It is set as follows when shipped.



- ON Energization type: Half step
- OFF ... Auto current down function

	ON	OFF
1	Half step	Full step
2	Release	Set

Function change-over switch

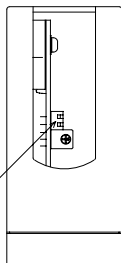

• Input signal terminal

• CW pulse input terminal

By applying the pulse input, the actuator moves from the motor side to the end side.

• CCW pulse input terminal

By applying the pulse input, the actuator moves from the end side to the motor side.

• Power down input terminal

By applying the "H" level input, the motor current is shut off and the motor becomes de-energized.

• Functions

• Auto current down

This is a function that reduces the motor current to half when the motor stops. This will prevent the motor and driver from generating heat. Although auto current down causes the holding torque to be reduced when the motor stops, the holding torque that supports the actuator transfer load is maintained.

• Power down

This function shuts off the motor current and de-energizes the motor. Use this function to release the electric actuator for maintenance, etc.

Positioning driver

Series LC6C Series LX Dedicated



How to Order

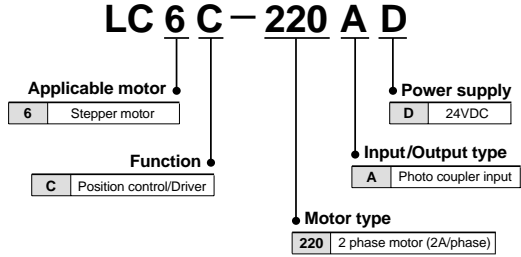

- Built-in position control function added to LC6D
- Up to 28 patterns of movement data can be set.
- Point movement can be easily achieved with a PLC, etc.
- Compatible with Series LX two phase stepper motor

Applicable Actuators

Driver	Applicable actuator		Motor type
LC6C-220AD	Guide rod type	LXPB2	2 phase stepper motor
	High rigidity slide table type	LXSH2	

* Select a 3 wire NPN type when using an auto switch.

Specifications

Part no.	LC6C-220AD
Power supply	24VDC ±10%, Max. 3.0A
Number of position settings	28 patterns
Position setting method	Setting with dedicated teaching box (LC5-1-T1-02)
Position control method	Absolute and incremental moves Speed: 6 to 200mm/s (with lead screw lead of 12mm)
Input signal capacity	Photo coupler input 24VDC, Max. 6mA
Output signal capacity	Photo coupler output Max. 30VDC or less, Max. 20mA
Parameter setting	Position data setting, Speed/Acceleration setting, etc.
Indication LED	Power supply LED, Alarm LED
Operating temperature	5° to 40°C
Accessories	Power connector, Interface connector (Cables should be arranged by customer.)

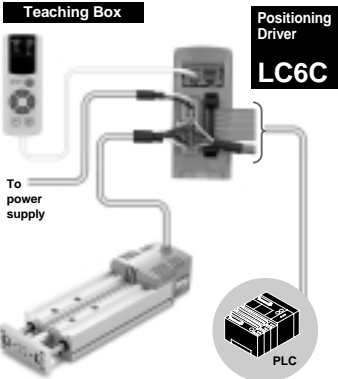

(Should be arranged by customer.)

Electric Actuator

Absolute and incremental moves for each movement pattern.

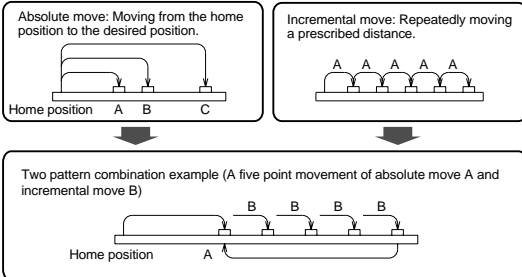

Eight speed patterns based on the speed number and acceleration number can be set, and a speed pattern can be selected for each movement pattern.

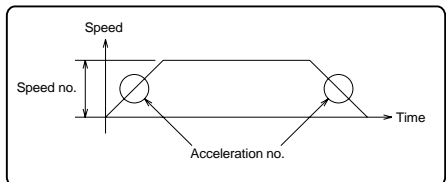

Series LC6C

Dimensions

LC6C-220AD

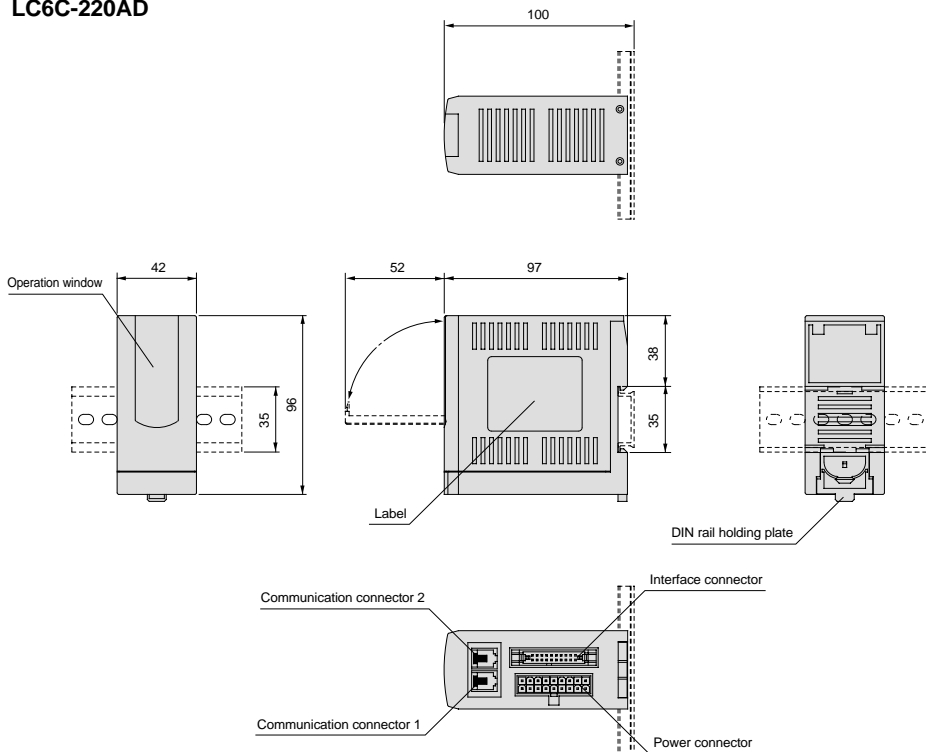

Connection Example

Wiring to the teaching box

By connecting multiple drivers (maximum of 16), they can be set by one teaching box.
(When the teaching box is in use, external input to the drivers become invalid.)

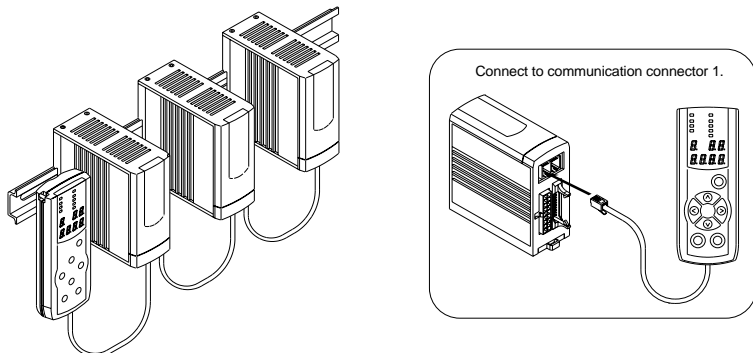

Connection Examples

Power connector wiring

Connector: Power connector (included)
 Manufacturer: Molex Japan, Co., Ltd.
 Part no.: Receptacle 5557-18R
 Female terminal 5556PBTL

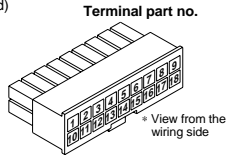

Switches

Home position switch: This switch indicates the home position. Connect this switch when returning to the origin point. This switch also acts as a sensor that detects overrun in the motor direction.

Limit switch: This sensor detects overrun in the end direction. Connect this switch as needed.

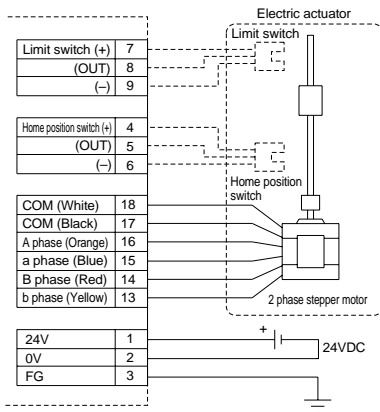

Interface connector wiring

Connector: Interface connector (included)
 Manufacturer: OMRON Corporation
 Part no.: Connector XG4M-2030-T

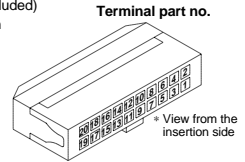

A ▽ mark is located on the connector number 1 side.

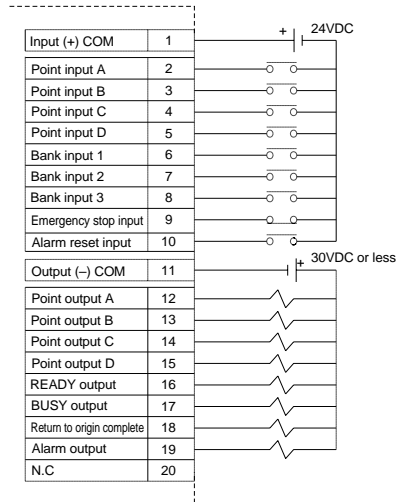

Power connector input/output signal details

Connector no.	Signal description	Detail
1	24V	Connect to power supply (+24VDC)
2	0V	Connect to power supply (0V)
3	FG	Connect to frame ground
4	Home position switch (+)	Connect to home position switch positive power supply line
5	Home position switch (OUT)	Connect to home position switch output line
6	Home position switch (-)	Connect to home position switch 0V power supply line
7	Limit switch (+)	Connect to limit switch positive power supply line
8	Limit switch (OUT)	Connect to limit switch output line
9	Limit switch (-)	Connect to limit switch 0V power supply line
10	N.C.	Do not connect.
11	N.C.	Do not connect.
12	N.C.	Do not connect.
13	b phase (Yellow)	Connect to actuator power line (Yellow)
14	B phase (Red)	Connect to actuator power line (Red)
15	a phase (Blue)	Connect to actuator power line (Blue)
16	A phase (Orange)	Connect to actuator power line (Orange)
17	COM (Black)	Connect to actuator power line (Black)
18	COM (White)	Connect to actuator power line (White)

⚠ Caution

Use a 3 wire NPN type for each switch.

Interface connector input/output signal details

Connector no.	Signal description	Details
1	Input (+) COM	Input COM signal
2	Point input A	Point setting input (point A)
3	Point input B	Point setting input (point B)
4	Point input C	Point setting input (point C)
5	Point input D	Point setting input (point D)
6	Bank input 1	Bank setting input (binary, first bit)
7	Bank input 2	Bank setting input (binary, second bit)
8	Bank input 3	Bank setting input (binary, third bit)
9	Emergency stop input	Emergency stop input
10	Alarm reset input	When an alarm occurs, this signal turns off the alarm after the cause is resolved.
11	Output (-) COM	Output COM signal (GND)
12	Point output A	This signal indicates move completion for point input A.
13	Point output B	This signal indicates move completion for point input B.
14	Point output C	This signal indicates move completion for point input C.
15	Point output D	This signal indicates move completion for point input D.
16	READY output	This signal indicates that the controller is ready.
17	BUSY output	This signal indicates motor control in progress.
18	Home position return output	This signal indicates that home position return is completed.
19	Alarm output	This signal indicates occurrence of alarm.
20	N.C.	Do not connect.

⚠ Caution

If input is not provided as prescribed for the operation, this may cause malfunction or failure.

Series LC6C

Home Position Return

1 Operation

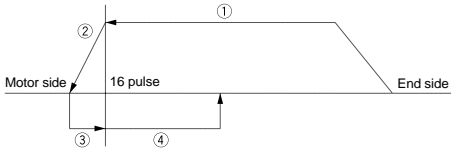

Home position sensor position

- ① Moves to the motor side at home position return speed
- ② Decelerates and stops at the home position sensor ON position
- ③ Moves to the end side at low speed
- ④ Moves and stops at 16 pulse position from the home position sensor OFF position

2 Operating procedures

1. Confirm that both READY output and alarm output are ON.
2. Turn OFF bank inputs 1 to 3. [Specify bank 0.]
3. When point input A is turned ON, the actuator begins to return to the home position.
4. BUSY output is turned ON during home position return.
5. BUSY output is turned OFF when the actuator reaches the home position, and home position return output turns ON.
6. Turn OFF point input A.

Note) The actuator stops if point input A is turned OFF when BUSY output is ON (home position return movement in progress).

3 Home position return speed

Speed is set by parameter number 0D.

1. 015

Acceleration no. Speed no.

4 Home position return signal

This signal output turns ON when the home position return movement completes. It turns OFF when an alarm occurs or when JOG movement takes place.

5 Time chart

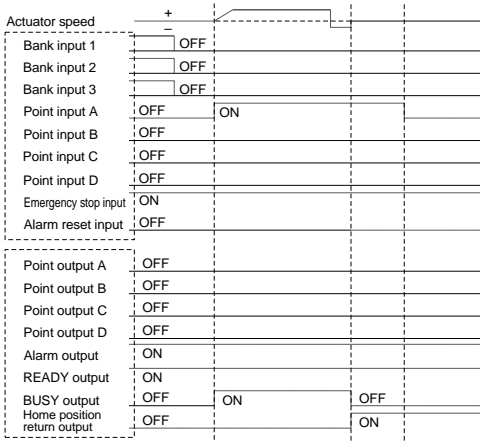

Point Movement

With this driver, a maximum of 28 point positions can be set by combining banks and points. With the combination of bank and point inputs, the actuator can move to the position indicated by each point.

1 Setting detail

To set point settings, use the parameter setting and teaching functions of the dedicated teaching box.

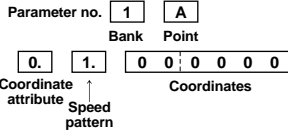

2 Operating procedures

1. Confirm that both READY output and alarm output are ON.
2. Set bank with bank inputs 1 to 3. [Bank 1 to 7.]
3. When points are specified with point inputs A to D, the actuator starts to move.
4. BUSY output is ON while the actuator is moving.
5. BUSY output turns OFF when the move completes and point outputs A to D turn ON. These correspond to point inputs A to D that are ON.
6. When point inputs A to D are turned OFF, point outputs A to D turn OFF.

Note) The actuator stops moving if point inputs A to D are turned OFF or two or more of point inputs A to D are turned ON while BUSY output is ON (during movement).

3 Time chart (when specifying point B)

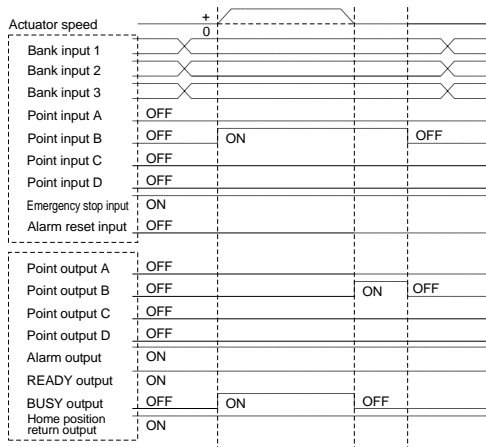



Performance/Specifications

General specifications

Part no.	LC5-1-T1-02
Power supply	Supplied by LC6C-220AD
Dimensions	130mm x 50mm x 21mm
Weight	110g
Body type	Resin body
Indication unit	7 LED numerical indicators, 9 LED indicator lights
Operation unit	Key switches
Cable length	2m

Basic performance

	Performance/Specifications
Applicable controller	LC6C-220AD
Operating temperature range	5° to 40°C
Communication method	Conforming to RS485
Functions	Parameter change, JOG operation, alarm reset, teaching, test
Protective function indication	Alarm code

Dimensions

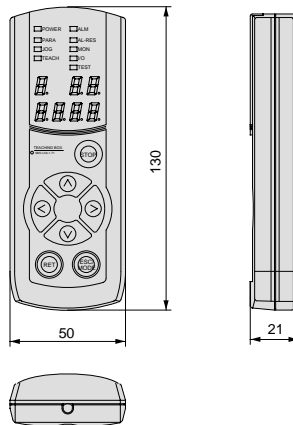

LJ1

LG1

LC1

LX

LC6D/LC6C

Switches

Series LC6C

Part Descriptions

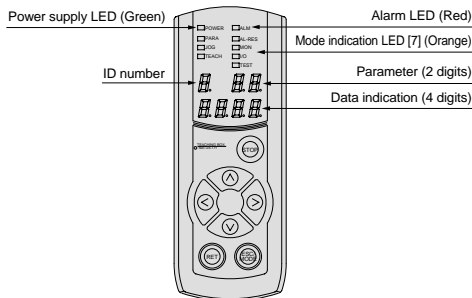

Operating Method

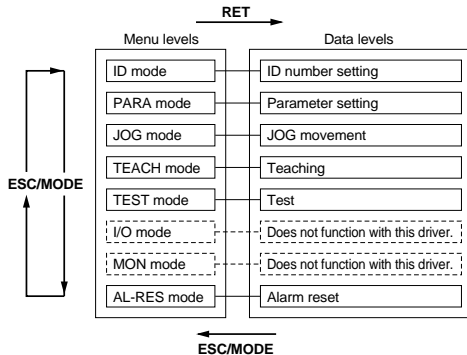

Key Arrangement and Functions

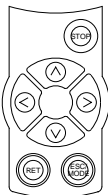

As shown above, 6 modes are available. (I/O mode and MON mode do not function with this driver.) When the communication mode is started by the teaching box, a menu can be selected with [ESC/MODE]. Select the mode indication LED for the mode to be implemented (all mode indication LEDs turn Off in the ID mode) and press [RET] to start each mode.

Refer to the instruction manual for the operation of each mode.

Mark	Key description	Function
∧	UP	Increases a numerical value.
∨	DOWN	Reduces a numerical value.
<	L	Moves a numerical value place to the left. Rotates the motor counter clockwise during JOG operation.
>	R	Moves a numerical value place to the right. Rotates the motor clockwise during JOG operation.
STOP	STOP	Becomes the emergency stop key when the actuator is moving.
ESC/MODE	ESC/MODE	Selects a mode. Completes each mode and returns to the mode level.
RET	RET	Determines the mode and records data.

⚠ Caution

STOP key only stops the driver that is in communication.

Alarm Details

Alarm no.	Alarm description	Presumed cause and solution
1	Emergency stop input	Emergency stop input is turned OFF (open).
2	Temperature abnormality	The temperature inside the driver is high. Check the installation environment and operation frequency.
3	Power supply abnormality	Operating beyond the range of the specified power supply. Adjust the power supply.
4	Limit switch abnormality	Home position switch and limit switch are operating. Malfunction such as loss of synchronism may have occurred. Check the equipment.

Series LC6D/LC6C Options

⚠ Caution

- Do not repeatedly apply bending stress or tension to the cables.
Wiring that subjects cables to repeated bending stress and tension causes line breakage.
- Make connections based on each driver's connection example.

LC6D Connector Cable

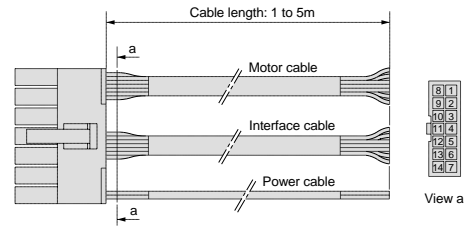
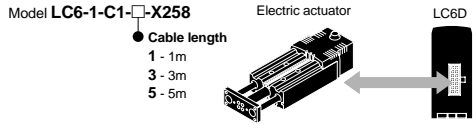

Wiring

Pin no.	Cable description	Signal description	Color	Pin no.	Cable description	Signal description	Color
1	Interface cable	PD+	Yellow	8	Interface cable	PD-	Brown
2		CCW+	Red	9		CCW-	Green
3		CW+	Black	10		CW-	White
4	Motor cable	Motor B	White	11	Motor cable	Motor F	Brown
5		Motor A	Black	12		Motor E	Yellow
6	Power cable	GND	Black	13		Motor D	Green
7		+24V	White	14		Motor C	Red

LC6C Power Connector Cable

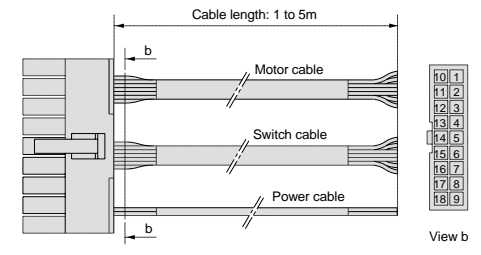
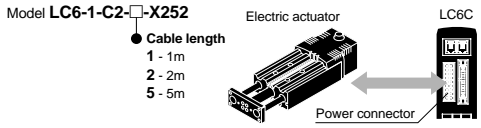

Wiring

Pin no.	Cable description	Signal description	Color
1	Power cable	+24V	White
2		0V	Black
3		FG	Red
4	Switch cable	Home position switch (+)	White
5		Home position switch (OUT)	Black
6		Home position switch (-)	Brown
7		Limit switch (+)	Yellow
8		Limit switch (OUT)	Green
9	Motor cable	Limit switch (-)	Red
13		Motor wire (Yellow)	Red
14		Motor wire (Red)	Green
15		Motor wire (Blue)	Yellow
16		Motor wire (Orange)	Brown
17		Motor wire (Black)	Black
18		Motor wire (White)	White

LC6C Interface Connector Cable

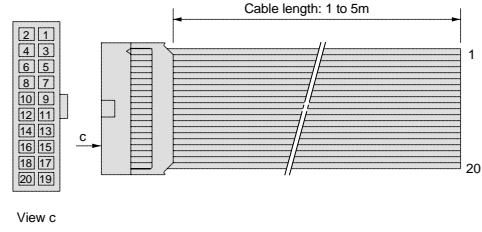
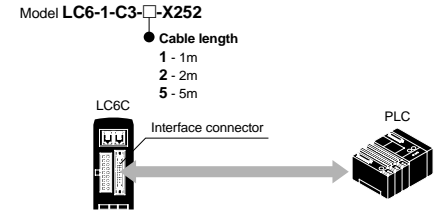

LC6C Driver Connection Cable

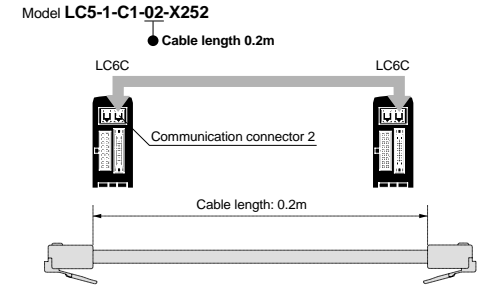

LJ1
 LG1
 LC1
 LX
 LC6D/LC6C
 Switches