

Related Products: Heavy Duty Auto Drain Series ADH4000

Easy maintenance

It is possible to maintain without changing existing piping.

No need for electric power and no waste of air.

Float style drain allows automatic drain discharge without electric power.

Mounting example

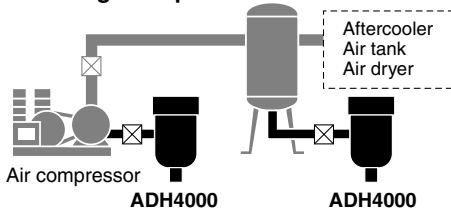

JIS Symbol

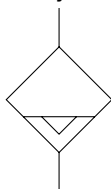

Specifications

Auto-drain type	Float type
Auto-drain valve type	N.O. (Normally open: Open in the case of pressure loss)
Proof pressure	2.5 MPa
Max. operating pressure	1.6 MPa
Operating pressure range ^{Note)}	0.05 to 1.6 MPa
Fluid ^{Note)}	Compressed air
Ambient and Fluid temperature	5 to 60°C (With no condensation) <Corrosive gas, flammable gas and organic solvents are not allowed.>
Max. drain discharge	400 cc/min (Pressure 0.7 MPa, in the case of water)
Weight	1.2 kg (With bracket: 1.3 kg)
Paint color	Light gray

Note) Use for air compressor with flow more than 50 ℓ/min (ANR).

Accessory (Option)

Description	Part no.	Contents
Bracket set	BM58	Bracket 1 pc. M6 x 10ℓ (Hex. bolt) 2 pcs.
Ball valve piping set	ADH-C400	Ball valve/Rc 1/2 1 pc. Barrel nipple/R 1/2 2 pcs. Elbow/Rc 1/2 1 pc.

Note) The accessories (Option) are shipped unassembled, but packed in the same container.

How to Order

ADH4000 — **04** **04**

Heavy duty auto-drain

Basic size

Thread type

Nil	Rc
F	G
N	NPT

Accessory (Option) *

Nil	No option (Standard)
B	Bracket set
C	Ball valve piping set

* Notes

- 1) When more than one option is desired, list in alphabetical order.
- 2) Accessories are not factory assembled.
- 3) Refer to each drawing for details of dimensions and mounting methods.
- 4) Accessory "C" is available only with Rc thread.

Port size

04	1/2 (Female thread)
----	---------------------

HA

AT

ID

AMG

AFF

AM

Misc.

Series ADH4000

Construction

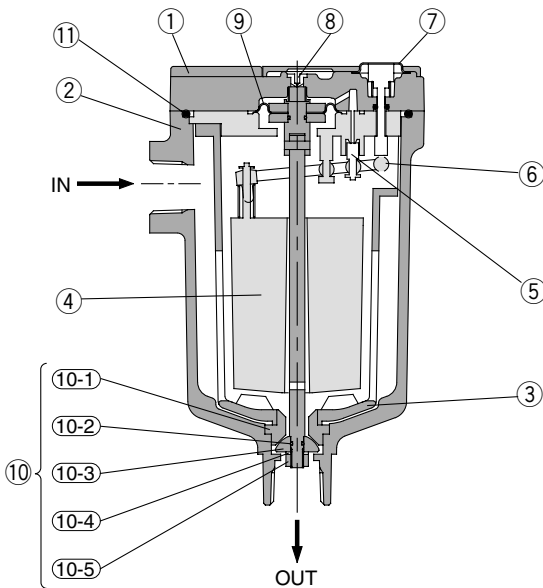

Component Parts

No.	Description	Material	Note
①	Body	Aluminum alloy	Baking finish
②	Housing	Aluminum alloy	Baking finish
③	Drain guard	Aluminum alloy	Baking finish
④	Float	Foam rubber	
⑤	Pilot valve	Stainless steel + Rubber	
⑥	Lever	Resin	
⑦	Flushing button	Brass	
⑧	Orifice		
⑨	Diaphragm	Rubber	

Replacement Parts

No.	Description	Part no.	Note
⑩	Repair kit for main valve	ADH-D400	Kit includes parts from 10-1 to 10-5.
⑪	O-ring	G85(B)	Material: NBR

Note) When changing parts, follow the instruction manual.
Do not disassemble other parts.

⚠ Precautions

Be sure to read before handling. Refer to pages 14-21-3 to 4 for Safety Instructions and Common Precautions on the products mentioned in this catalog, and pages 14-14-6 to 8 for Precautions on every series.

Caution on Design

⚠ Caution

1. Operate this product in an area in which the air pressure does not exceed 1.6 MPa.
If this value is exceeded, it could lead to an accident or malfunction.
2. An air pressure of 0.05 MPa and an air compressor's discharge flow rates higher than 50 l/min (ANR) are required.
Below these values, the air will continue to be discharged from the drainage discharge port.
3. Keep the compressed air temperature and the ambient temperature of the location in which this product is installed within the range of 5 to 60°C. Exceeding this range could lead to failure or malfunction.
4. Avoid operating this product in an area in which corrosive gases, flammable gases or organic solvents are contained in the compressed air or in the surrounding air.

Selection

⚠ Caution

1. The maximum dischargeable drainage rate is 400 cc/min.
If the product is operated in excess of this value, there is a risk of causing the drainage to flow over to the outlet side.

Piping

⚠ Caution

1. Use piping of 1/2B bore size or larger for drain inlet and allow for unobstructed flow-in for drain.
2. Drain line should be 8 mm or more in diameter and less than 10 m in length. Do not make any upward angles in drain line. Be sure to secure exhaust port piping since drain is under pressure.

Mounting

⚠ Caution

1. Install with "out port" down in a vertical position.
Inclination from the vertical line should be less than 5°.
2. Install with at least 200 mm of free space above the unit to allow for maintenance.
3. To place this product near the air compressor, install in such a way that the vibrations will not be transmitted.
4. Install a valve to drain inlet so that maintenance is possible.
Use a ball valve with a bore size of more than 15 mm to ensure proper flow-in of drain. (Ball valve piping set is available as optional accessory.)
5. When not draining sufficiently, adjust the open angle of its bleed valve to lower the pressure inside the case, so that drainage will run through easily.

Maintenance

⚠ Caution

1. Check drain condition periodically (more than once a day).
Then push flushing button to open exhaust valve.
2. Pilot air is exhausted from the exhaust port indicated in the "Dimensions" section. **Do not cover this exhaust port.** Clean exhaust port so that port is not blocked by dust, etc.
3. When solid foreign objects exceeding 1 mm comes in, the main valve may become blocked. After recovering the internal pressure of this product to 0 MPa (atmospheric pressure), remove the hexagon socket head bolt (M6) from the body part and wash inside with water to remove foreign solid particles blocking the main valve.
4. While operating, there may be cases where drainage will not easily enter this product. In such a case, adjust the open angle of its bleed valve to lower the pressure a bit inside the bowl, so that drainage will run through easily.

Heavy Duty Auto drain Series ADH4000

Dimensions

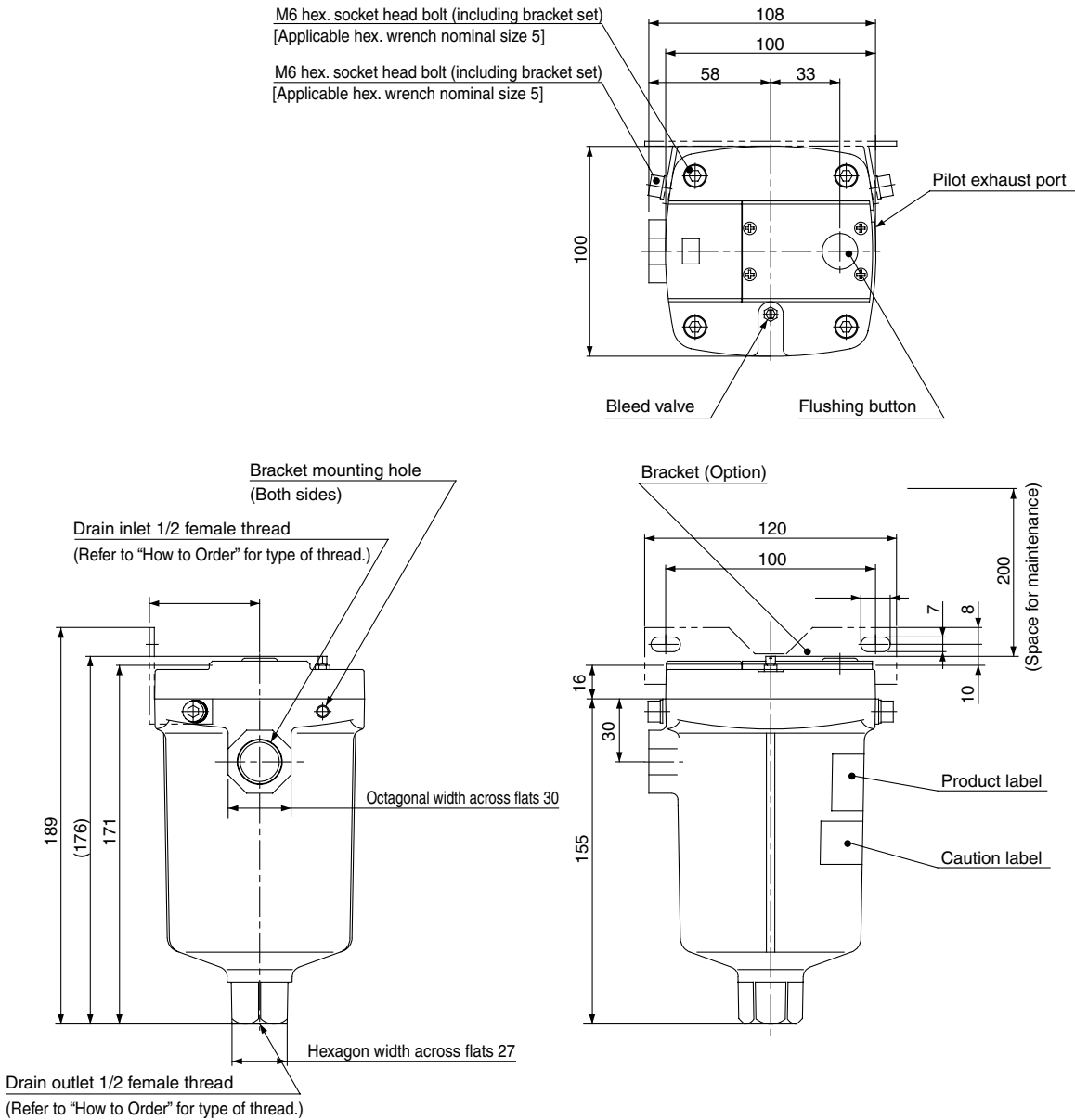

Option: Reference Figure of Assembly

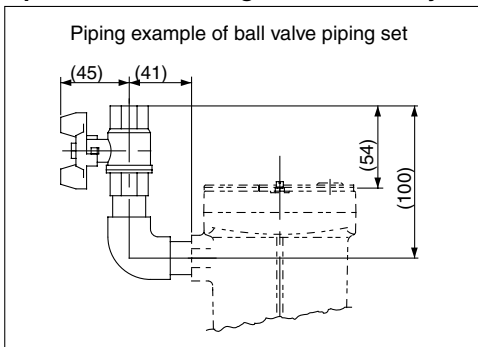

- HA
- AT
- ID
- AMG
- AFF
- AM
- Misc.