



Large Size 3 Port Solenoid Valve Rubber Seal

Series VP3145/3165/3185

Large flow capacity, small exhaust resistance

(Refer to "Flow Characteristic" table.)

Easy conversion to N.C. or N.O.

Function plate makes it possible to use as a N.C. or N.O. valve with the port unchanged.

Possible to use in vacuum or under low pressures

External pilot type

Vacuum: Up to 101.2 kPa

Low pressure: 0 to 0.2 MPa

Free mounting orientation

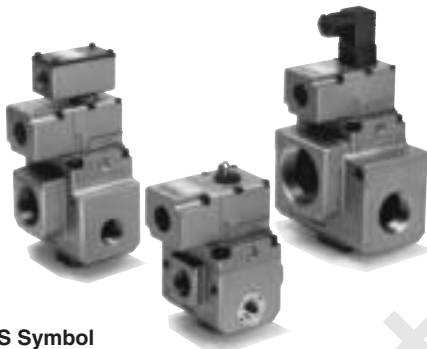

JIS Symbol

Internal pilot
<Standard>

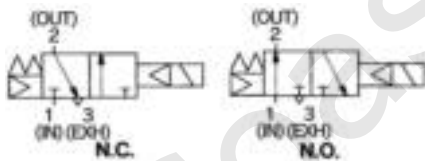

External pilot

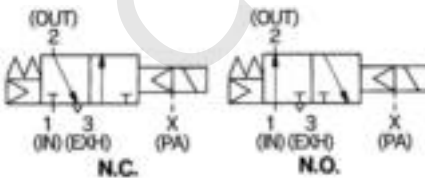

Note) N.O. valve operates properly only when appropriate pressure is applied to the pilot.



Made to Order Specifications
(For details, refer to page 4-10-8.)

How to Order

VP3 1 4 5 **04 1 G A**

Series VP 3 port solenoid valve

Number of solenoids

1	Single
---	--------

Body size

4	1/2
6	1
8	1 1/2

Body type

5	Body ported
---	-------------

Valve option

Nil	For general
V	For vacuum/low pressure

Port size (IN, OUT port)

Symbol	Port size Rc (Nominal size)	VP3145	VP3165	VP3185
03	3/8 (10A)	●		
04	1/2 (15A)	●		
06	3/4 (20A)	●	●	
10	1 (25A)		●	
12	1 1/4 (32A)		●	●
14	1 1/2 (40A)			●
20	2 (50A)			●

Thread type

Nil	Rc
F	G
N	NPT
T	NPTF

Pilot option

Nil	Standard (Internal pilot)
1	External pilot

Type of actuation

A	N.C. (Normally closed)
B	N.O. (Normally open)

Electrical entry

G	Grommet
T	Conduit terminal
D	DIN terminal
TL*	Conduit terminal with indicator light
TS*	Conduit terminal with surge voltage suppressor
TZ*	Conduit terminal with light/surge voltage suppressor
DL*	DIN terminal with indicator light
DS*	DIN terminal with surge voltage suppressor
DZ*	DIN terminal with light/surge voltage suppressor

* Option

Coil rated voltage

1	100 VAC, 50/60 Hz
2	200 VAC, 50/60 Hz
3*	110 VAC, 50/60 Hz
4*	220 VAC, 50/60 Hz
5	24 VDC
6*	12 VDC
7*	240 VAC, 50/60 Hz
9*	Other

* Option

V100

SY

SYJ

VK

VZ

VT

VP

VG

VP

S070

VQ

VKF

VQZ

VZ

VS

VFN

How to Order Pilot Valve Assembly

VT3113 - 00 1 G

Coil rated voltage

1	100 VAC, 50/60 Hz
2	200 VAC, 50/60 Hz
3*	110 VAC, 50/60 Hz
4*	220 VAC, 50/60 Hz
5	24 VDC
6*	12 VDC
7*	240 VAC, 50/60 Hz
9*	Other

* Option

Electrical entry

G	Grommet
T	Conduit terminal
D	DIN terminal
TL*	Conduit terminal with indicator light
TS*	Conduit terminal with surge voltage suppressor
TZ*	Conduit terminal with light/surge voltage suppressor
DL*	DIN terminal with indicator light
DS*	DIN terminal with surge voltage suppressor
DZ*	DIN terminal with light/surge voltage suppressor

* Option

Series VP3145/3165/3185

External Pilot

Use external pilot model in the following cases.

- Vacuum or low pressure (0.2 MPa or less):
Vacuum/Low pressure type
- Using the valve with supply port external throttle:
General type
- Air pressure of supply port is slow:
General type
- Resistance in outlet side is small in case of air blowing or filling an air tank:
General type

Note 1) Keep external pilot pressure within the pressure range below.

Note 2) Conversion of internal pilot and external pilot can not be done.

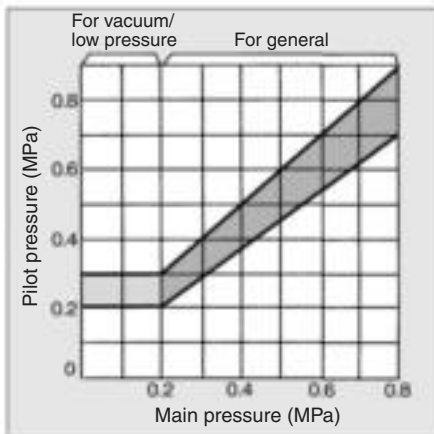

Specifications

Fluid		Air					
Type of actuation		N.C. or N.O. (Convertible)					
Pilot type		Internal pilot		External pilot			
		For general	For vacuum/low pressure	For general			
Operating pressure range (MPa)	Main pressure	0.2 to 0.8	-101.2 kPa to 0.2		0.2 to 0.8		
	Pilot pressure		0.2 to 0.3		Refer to the graph left.		
Ambient and fluid temperature (°C)		0 (No freezing) to 60					
Response time (ms) ⁽¹⁾ (at the pressure of 0.5 MPa)		ON	AC	30 or less	OFF	AC	30 or less
			DC	40 or less	DC	30 or less	
Max. operating frequency (Hz)		3					
Lubrication ⁽²⁾		Required (Equivalent to turbine oil Class1 ISO VG32)					
Manual override		Yes (Non-locking)					
Mounting orientation		Unrestricted					
Shock/Vibration resistance (m/s ²) ⁽³⁾		150/50					

Note 1) Based on dynamic performance test, JIS B 8374-1981. (Coil temperature: 20°C, at rated voltage, without surge voltage suppressor)

Note 2) This solenoid valve requires lubrication. Use turbine oil Class 1 (ISO VG32).

Note 3) Impact resistance: No malfunction occurred when it is tested with a drop tester in the axial direction and at the right angles to the main valve and armature in both energized and de-energized states every once for each condition. (Values at the initial period)

Vibration resistance: No malfunction occurred in a one-sweep test between 45 and 1000 Hz. Test was performed at both energized and de-energized states in the axial direction and at the right angles to the main valve and armature. (Values at the initial period)

Solenoid Specifications

Electrical entry	Standard	Grommet (G), Conduit terminal (T) DIN terminal (D)	
	Option	Conduit terminal with indicator light (TL), Conduit terminal with surge voltage suppressor (TS), Conduit terminal with light/surge voltage suppressor (TZ), DIN terminal with indicator light (DL), DIN terminal with surge voltage suppressor (DS), DIN terminal with light/surge voltage suppressor (DZ)	
Coil rated voltage (V)	AC ^(50/60 Hz)	100, 200, 110*, 220*, 240*	
	DC	12*, 24, 48*, 100*	
Allowable voltage fluctuation	-15 to +10% of rated voltage		
Apparent power ^{Note)}	AC	Inrush	73 VA (50 Hz), 58 VA (60 Hz)
		Holding	28 VA (50 Hz), 17 VA (60 Hz)
Power consumption ^{Note)}	DC	12 W	

* Option
Note) At rated voltage

Flow Characteristics/Weight

Valve model	Port size		Flow characteristics						Weight* (kg) Grommet
			1 → 2 (IN → OUT)			2 → 3 (OUT → EXH)			
	1 (IN), 2 (OUT)	3 (EXH)	C [dm ³ /(s·bar)]	b	Cv	C [dm ³ /(s·bar)]	b	Cv	
VP3145	3/8	3/4	19	0.43	5.5	18	0.47	5.4	
	1/2		23	0.32	6.2	21	0.39	5.8	
	3/4		28	0.36	7.6	26	0.35	7.0	

Valve model	Port size		Effective area (mm ²)		Weight* (kg) Grommet
	1 (IN), 2 (OUT)	3 (EXH)	1 → 2 (IN → OUT)	2 → 3 (OUT → EXH)	
VP3165	3/4	1 1/4	230	280	2.0
	1		280	310	
	1 1/4		310	330	
VP3185	1 1/4	2	570	650	2.8
	1 1/2		650	670	
	2		650	670	

* For grommet
Conduit terminal... +0.2 kg

Large Size 3 Port Solenoid Valve Rubber Seal Series VP3145/3165/3185

Construction/Internal Pilot

As in the figure below, this pilot-operated solenoid valve consists of a compact 3 port solenoid valve as the pilot valve and a large 3 port valve as the main valve.

The pilot valve controls opening and closing the main valve. N.C. or N.O. function conversion can be done by switching the pilot passage.

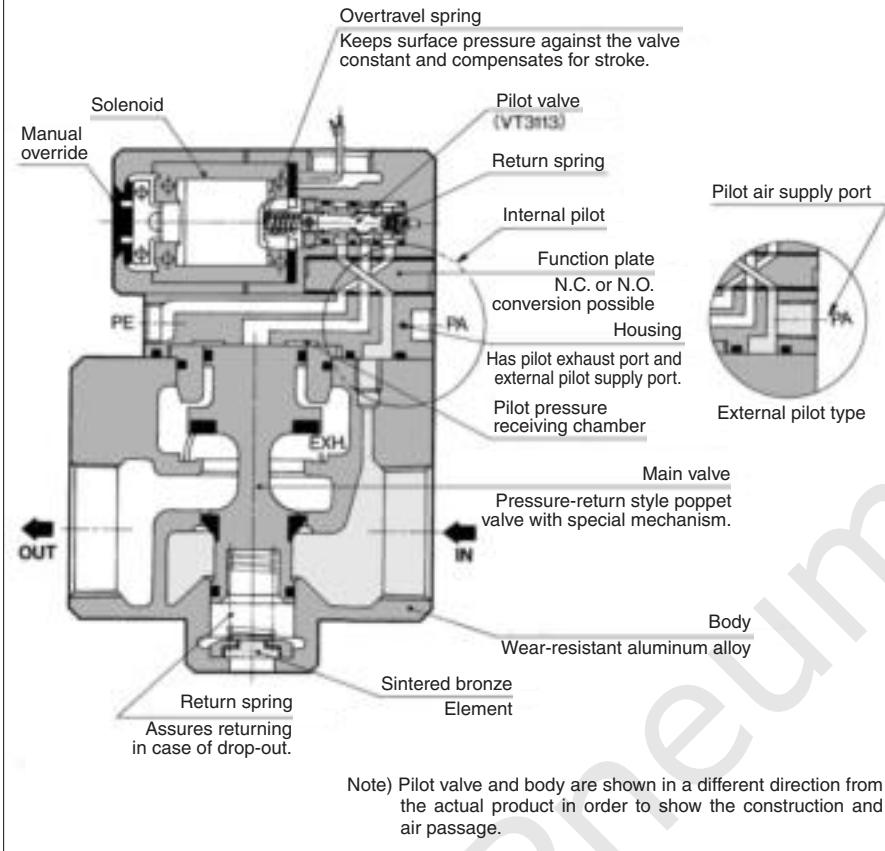

Piping (Vacuum Use)

1. Piping in general:

- EXH port = Vacuum pump/ Blower } (Suction side)
- OUT port = Vacuum pad/ Tank } (Load side)
- IN port = Plug (2 port valve)
Air releasing
Air pressure-in

2. Following the above piping, vacuum passage is switched between OUT and EXH, therefore, N.C./N.O. indication on the function plate and switching of the vacuum passage are reversed; N.C. (Normally closed) in vacuum passage are reversed:

- “N.C.” indicated on the plate
→ N.O. in vacuum passage
(Normally open)
- “N.O.” indicated on the plate
→ N.C. in vacuum passage
(Normally closed)

N.C./N.O. Conversion

To convert valve operation from N.C. to N.O. or N.O. to N.C., remove the pilot valve, move the function plate along the gasket, both top and bottom until the mark ► meets N.C. (N.O.)

Please note however, that the N.O. valve functions properly only when the appropriate pressure is applied to the valve.

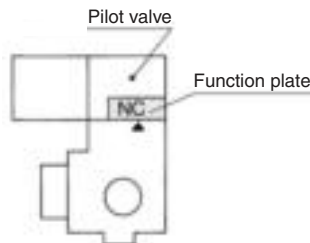

V100

SY

SYJ

VK

VZ

VT

VP

VG

VP

S070

VQ

VKF

VQZ

VZ

VS

VFN

Series VP3145/3165/3185

⚠ Precautions

Be sure to read before handling. For Safety Instructions and Solenoid Valve Precautions, refer to page 4-18-2.

⚠ Caution

Piping

If supply port air pressure drops to less than 0.2 MPa, the valve may malfunction. In such a case, use external pilot type. (When throttling IN port, or operating with OUT port open to the atmosphere or in a similar operation.)

Pressure balance among each port

This solenoid valve is pressure-unbalanced type. Operate it within this pressure range: $IN \geq OUT \geq EXH$. If not operated in the range, the valve will malfunction.

Use as 2 port valve

1. Plug EXH port in case of pressure-in and plug IN port in case of vacuum use.
2. This valve has slight air leakage and can not be used for such purposes as holding air pressure (including vacuum) in the pressure container.

Supply air

Install an air filter and a lubricator on the upstream side.

Lubrication

This solenoid valve requires lubrication. Use turbine oil Class 1 (ISO VG32). Besides that, for brands of each manufacturer, refer to page 4-18-5.

Environment

If using the valve in a dusty environment, install a silencer at EXH port and PE port to prevent dust from entering.

N.C./N.O. conversion

When changing the direction of a function plate to convert from N.C. to N.O. and vice versa, note that the equipment to be connected will cause a malfunction.

How to Calculate the Flow Rate

For obtaining the flow rate, refer to page 4-1-6.

Light/Surge Voltage Suppressor

	Grommet (G)	Conduit terminal (T)	DIN terminal (D)	
With indicator light (L)	None		48 VDC 	100 VAC
Surge voltage suppressor (S)				
With light/surge voltage suppressor (Z)	None		48 VDC 	100 VAC



Protection circuit for light/surge voltage suppressor is not the polarity type.

How to Use DIN Terminal

1. Disassembly

- 1) After loosening the thread (1), then if the cover (4) is pulled in the direction of the thread, the connector will be removed from the body of equipment (solenoid, etc.).
- 2) Pull out the screw (1), then remove the gasket (2a) or (2b).
- 3) On the bottom part of the terminal block (3), there's a cut-off part (indication of an arrow) (3a). If a small flat head screwdriver is inserted between the opening in the bottom, terminal block (3) will be removed from the cover (4). (Refer to the figure below.)
- 4) Remove the cable gland (5) and plain washer (6) and rubber seal (7).

2. Wiring

- 1) Pass them through the cable (8) in the order of cable ground (5), washer (6), rubber seal (7), and then insert into the housing (4).
- 2) Dimensions of the cable (8) are the figure as below. Skin the cable and crimp the crimped terminal (9) to the edges.
- 3) Remove the screw with washer (3e) from the bracket (3e). (Loosen in the case of Y-shape type terminal.) As shown in the below figure, mount a crimped terminal (9), and then again tighten the screw (3e).

Note) Tighten within the tightening torque of 0.5 N·m \pm 15%.

Note: a It is possible to wire even in the state of bare wire. In that case, loosen the screw with washer (3e) and place a lead wire (3d) into the bracket, and then tighten it once again.

b Maximum size of crimped terminal (9) is up to 1.25 mm²—3.5 when O terminal. For Y terminal, it is up to 1.25 mm²—4.

c Cable (8) external: ϕ 6 to ϕ 12 mm

Note) For the one with the external dimension ranged between 9 to 12 mm ϕ , remove the inside parts of the rubber seal (7) before using.

3. Assembly

- 1) Terminal block (3) connected with housing (4) should be reinstated. (Push it down until you hear the click sound.)
- 2) Putting rubber seal (7), plain washer (6), in this order into the cable introducing slit on the housing (4), then further tighten the cable gland (5) securely.
- 3) By inserting gasket (2a) or (2b) between the bottom part of the terminal block (3) and a plug on an equipment, screw in (1) on top of the housing (4) and tighten it.

Note) Tighten within the tightening torque of 0.5 N·m \pm 20%.

Note: The orientation of a connector can be changed arbitrarily, depending on the combination of a housing (4) and a terminal block (3).

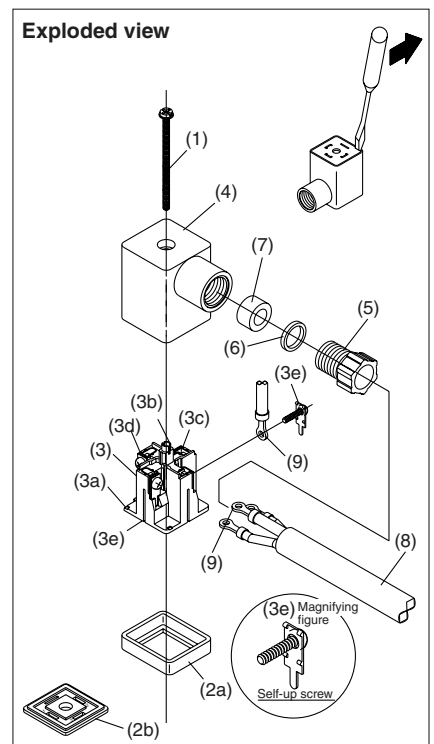

Large Size 3 Port Solenoid Valve Rubber Seal Series **VP3145/3165/3185**

Dimensions: VP3145

Grommet: VP3145□-□□G_B□

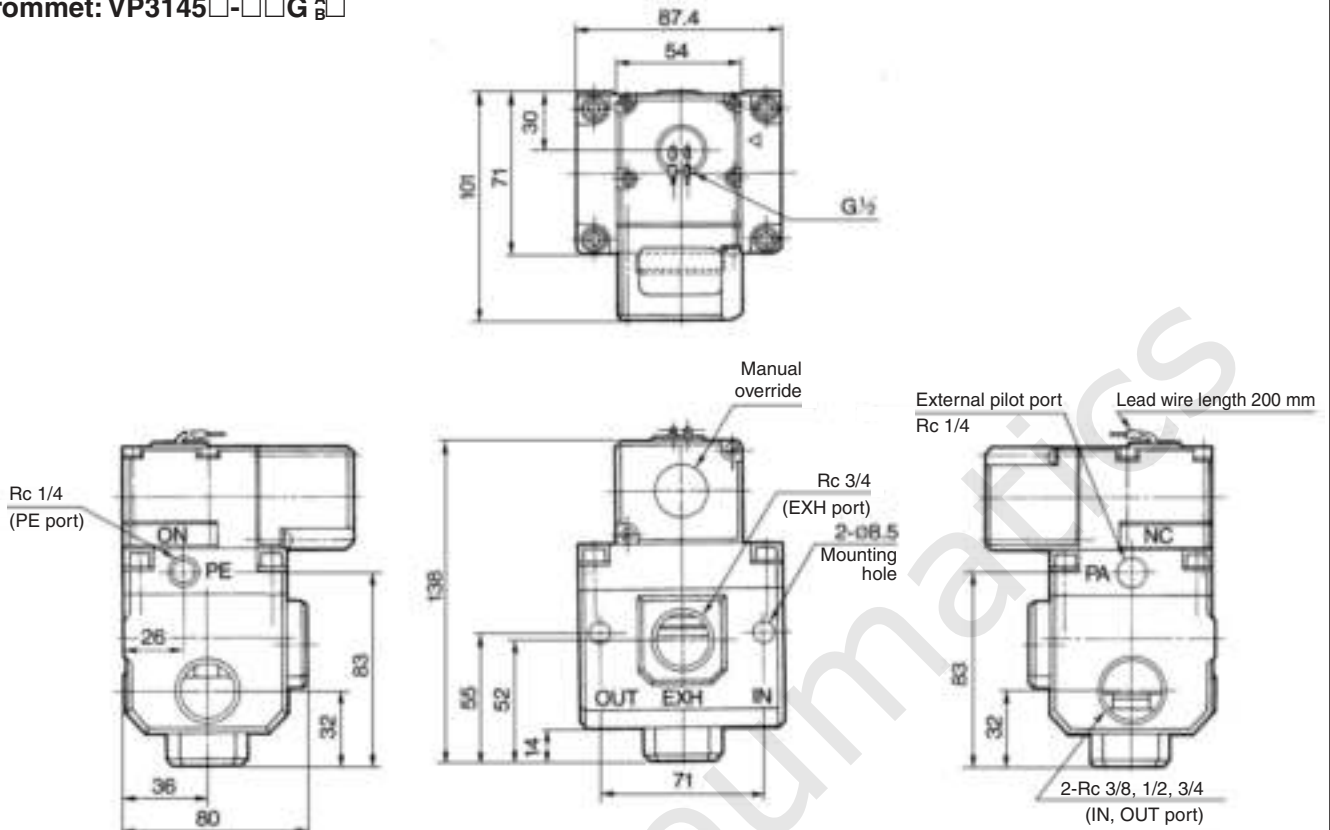

Note) External pilot port Rc 1/4 is processed for threads in external pilot model only.

Conduit terminal: VP3145□-□□T_B□

DIN terminal: VP3145□-□□D_B□

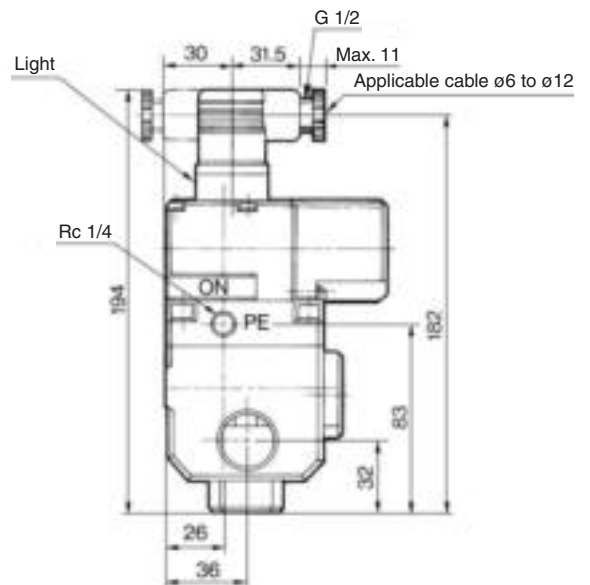
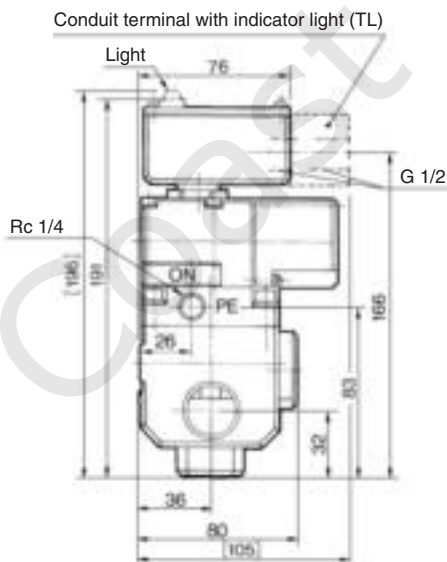

(): With indicator light (TL)

- V100
- SY
- SYJ
- VK
- VZ
- VT
- VP
- VG
- VP**
- S070
- VQ
- VKF
- VQZ
- VZ
- VS
- VFN

Series VP3145/3165/3185

Dimensions: VP3165

Grommet: VP3165□-□□G_B^A□

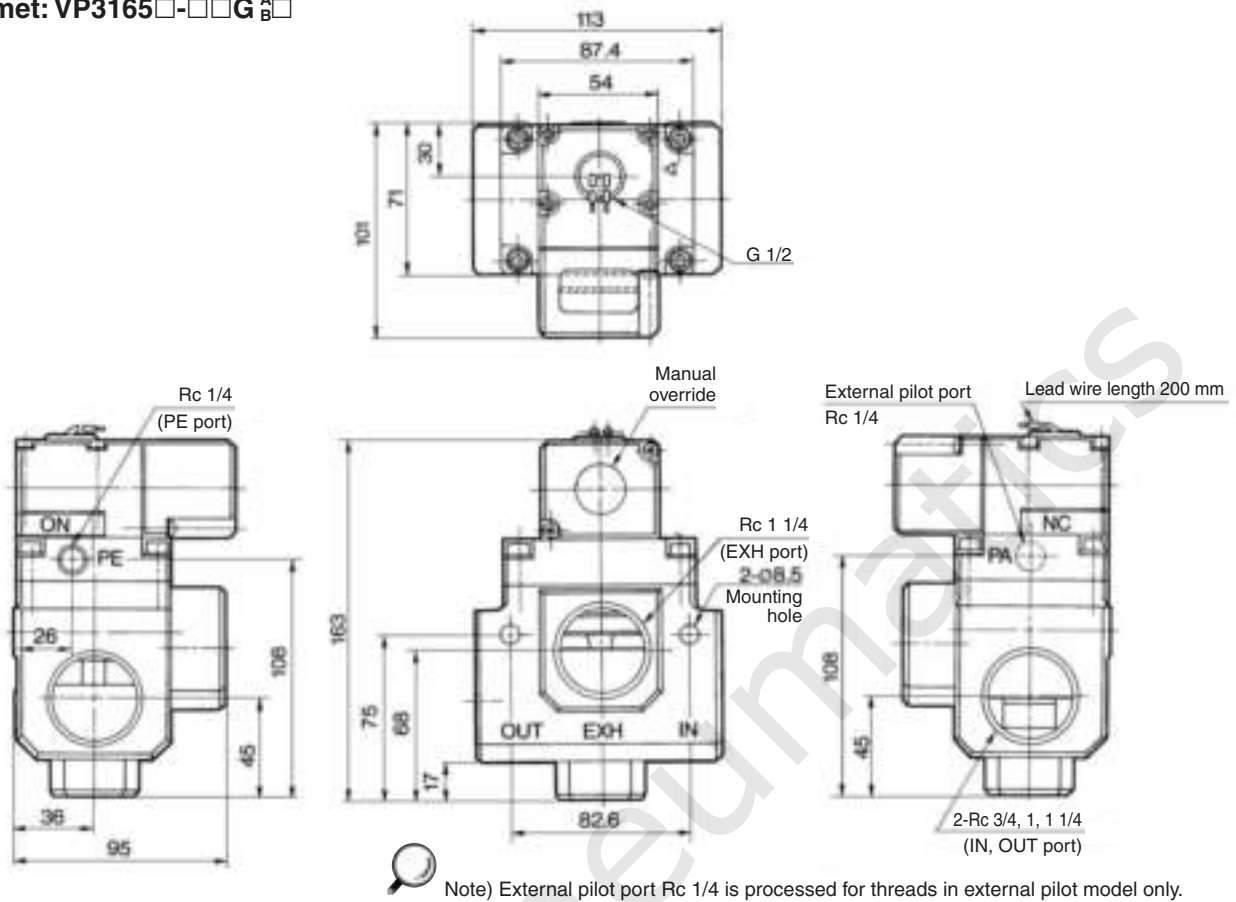

Conduit terminal: VP3165□-□□T_B^A□

DIN terminal: VP3165□-□□D_B^A□

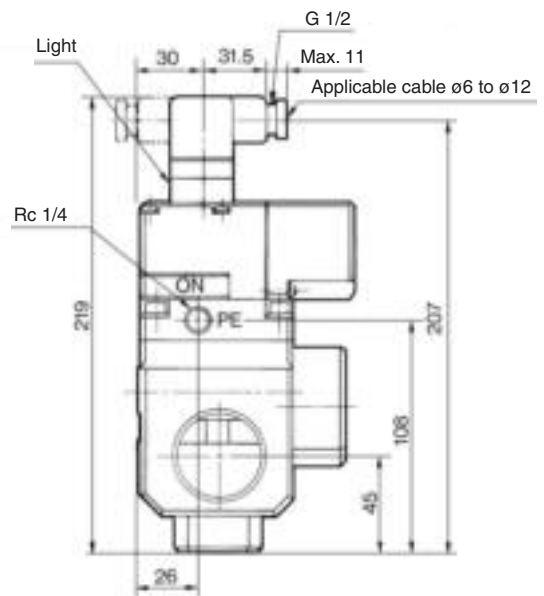
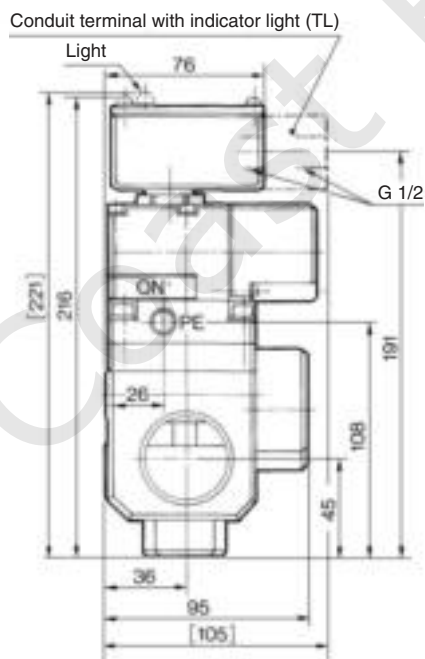

(): With indicator light (TL)

Large Size 3 Port Solenoid Valve Rubber Seal Series VP3145/3165/3185

Dimensions: VP3185

Grommet: VP3185□-□□G_A□_B□

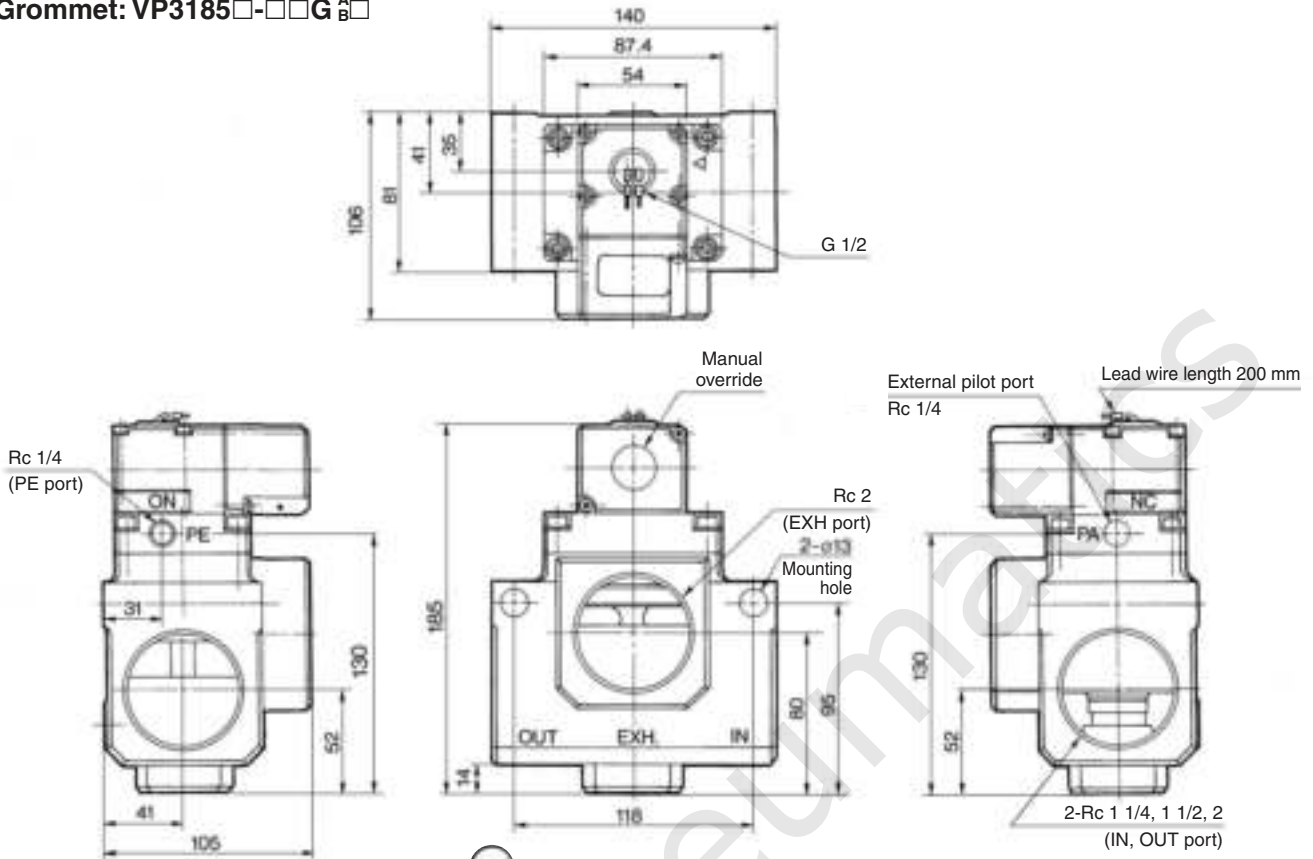

Note) External pilot port Rc 1/4 is processed for threads in external pilot model only.

Conduit terminal: VP3185□-□□T_A□_B□

DIN terminal: VP3185□-□□D_A□_B□

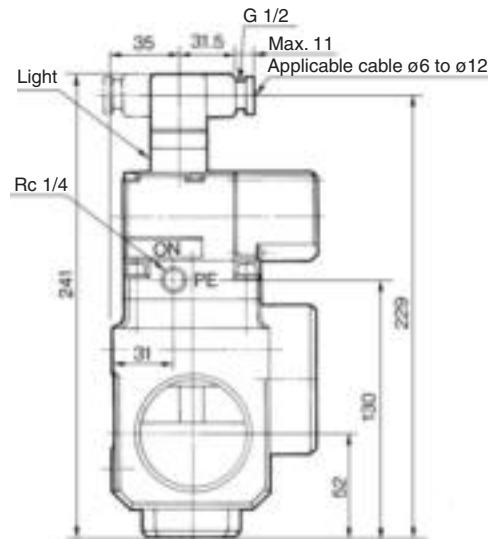
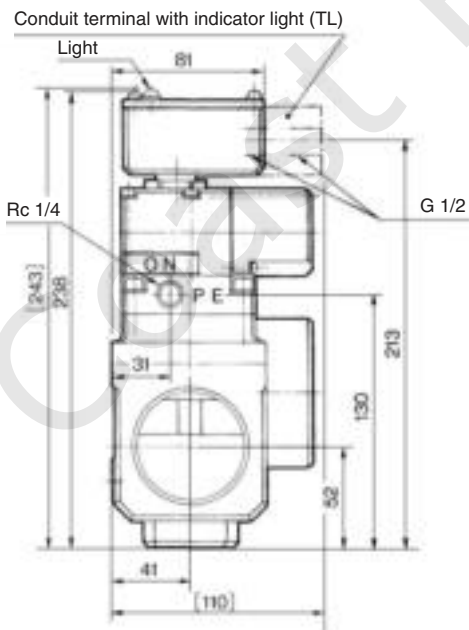

(): With indicator light (TL)

- V100
- SY
- SYJ
- VK
- VZ
- VT
- VP
- VG
- VP**
- S070
- VQ
- VKF
- VQZ
- VZ
- VS
- VFN

Made to Order Specifications:

Series VP3145/3165/3185

Main Valve Double Acting Type: -X80/X81

How to Order

VP31 4 5-06 1 D Z A 1-N-X 81

Body size

4	1/2
6	1
8	1 1/2

Port size (IN, OUT port)

Symbol	Port size	VP3145	VP3165	VP3185
03	3/8	○		
04	1/2	○		
06	3/4	○	○	
10	1		○	
12	1 1/4		○	○
14	1 1/2			○
20	2			○

Coil rated voltage

1	100 VAC, 50/60 Hz
2	200 VAC, 50/60 Hz
3*	110 to 120 VAC, 50/60 Hz
4*	220 VAC, 50/60 Hz
5	24 VDC
6*	12 VDC
7*	240 VAC, 50/60 Hz
9*	Other

* Option
L, M plug connector is 220 VAC at the maximum.

Type of actuation

80	Double solenoid
	Single solenoid

Thread type

Nil	Rc
F	G
N	NPT
T	NPTF

Passage, Type of actuation

A	N.C.
B	N.O.

In the case of -X80, only N.C. is available.

Light/Surge voltage suppressor

Nil	None
Z	With light/surge voltage suppressor
S	With surge voltage suppressor

* Indicator light is not available for grommet type. W/ surge voltage suppressor is available for grommet type only.

Electrical entry

G	Grommet (Lead wire: 300 mm)	
H	Grommet (Lead wire: 600 mm)	
E	Grommet terminal	
T	Conduit terminal	
D	DIN terminal	With connector
DO		Without connector
L	L plug connector	With lead wire
LN		Without lead wire
LO	M plug connector	Without connector
M		With lead wire
MN	M plug connector	Without lead wire
MO		Without connector

How to Order Pilot Valve Assembly

VF3 [] 40- [] [] []

Type of actuation

1	Single solenoid
2	Double solenoid

Coil rated voltage

1	100 VAC, 50/60 Hz
2	200 VAC, 50/60 Hz
3*	110 to 120 VAC, 50/60 Hz
4*	220 VAC, 50/60 Hz
5	24 VDC
6*	12 VDC
7*	240 VAC, 50/60 Hz
9*	Other

* Option
L, M plug connector is 220 VAC at the maximum.

Light/Surge voltage suppressor

Nil	None
Z	With light/surge voltage suppressor
S	With surge voltage suppressor

* Indicator light is not available for grommet type. W/ surge voltage suppressor is available for grommet type only.

Electrical entry

G	Grommet (Lead wire: 300 mm)	
H	Grommet (Lead wire: 600 mm)	
E	Grommet terminal	
T	Conduit terminal	
D	DIN terminal	With connector
DO		Without connector
L	L plug connector	With lead wire
LN		Without lead wire
LO	M plug connector	Without connector
M		With lead wire
MN	M plug connector	Without lead wire
MO		without connector

Large Size 3 Port Solenoid Valve Rubber Seal Series VP3145/3165/3185

JIS Symbol

-X80

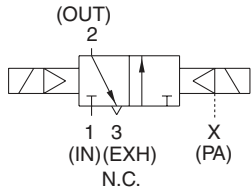

-X81

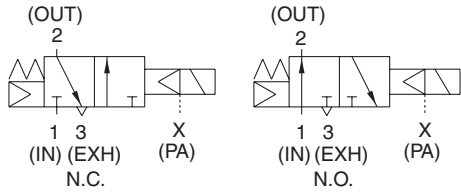

Specifications

Valve configuration	External pilot 3 port solenoid valve
Type of actuation	Double solenoid (-X80), Single solenoid (-X81)
Fluid	Air
Operating pressure range	-101.2 kPa to 0.8 MPa
Pilot pressure	85 to 115% of main pressure, Min. 0.2 MPa
Ambient and fluid temperature	0 to 50°C (No freezing)
Lubrication ⁽¹⁾	Required (Equivalent to turbine oil Class 1 ISO VG32)
Mounting orientation	Unrestricted
Impact/Vibration resistance ⁽²⁾	150/50 m/s ²

- Note 1) This solenoid valve requires lubrication. Use turbine oil Class 1 (ISO VG32).
 Note 2) Impact resistance: No malfunction occurred when it is tested with a drop tester in the axial direction and at the right angles to the main valve and armature in both energized and de-energized states every once for each condition. (Values at the initial period)
 Vibration resistance: No malfunction occurred in a one-sweep test between 45 and 1000 Hz. Test was performed at both energized and de-energized states in the axial direction and at the right angles to the main valve and armature. (Values at the initial period)

Solenoid Specifications

Electrical entry	Grommet, Grommet terminal, Conduit terminal DIN terminal, L plug connector, M plug connector	
Coil rated voltage (V)	AC (50/60 Hz)	100, 200, 12*, 24*, 48*, 110*, 220*, 240*
	DC	24, 6*, 12*, 48*, 100*, 110*
Allowable voltage fluctuation	-15 to 10%	
Apparent power (AC) ^{Note}	Inrush	5.6 VA/50 Hz, 5.0 VA/60 Hz
	Holding	3.4 VA/50 Hz, 2.3 VA/60 Hz
Power consumption (DC) ^{Note}	W/o indicator light	1.8 W
	W/ indicator light	2 W

- * Option
 Note) At rated voltage

Caution

Piping and other usage are the same as standard products.

Dimensions

VP3145-□□DZA1-X81

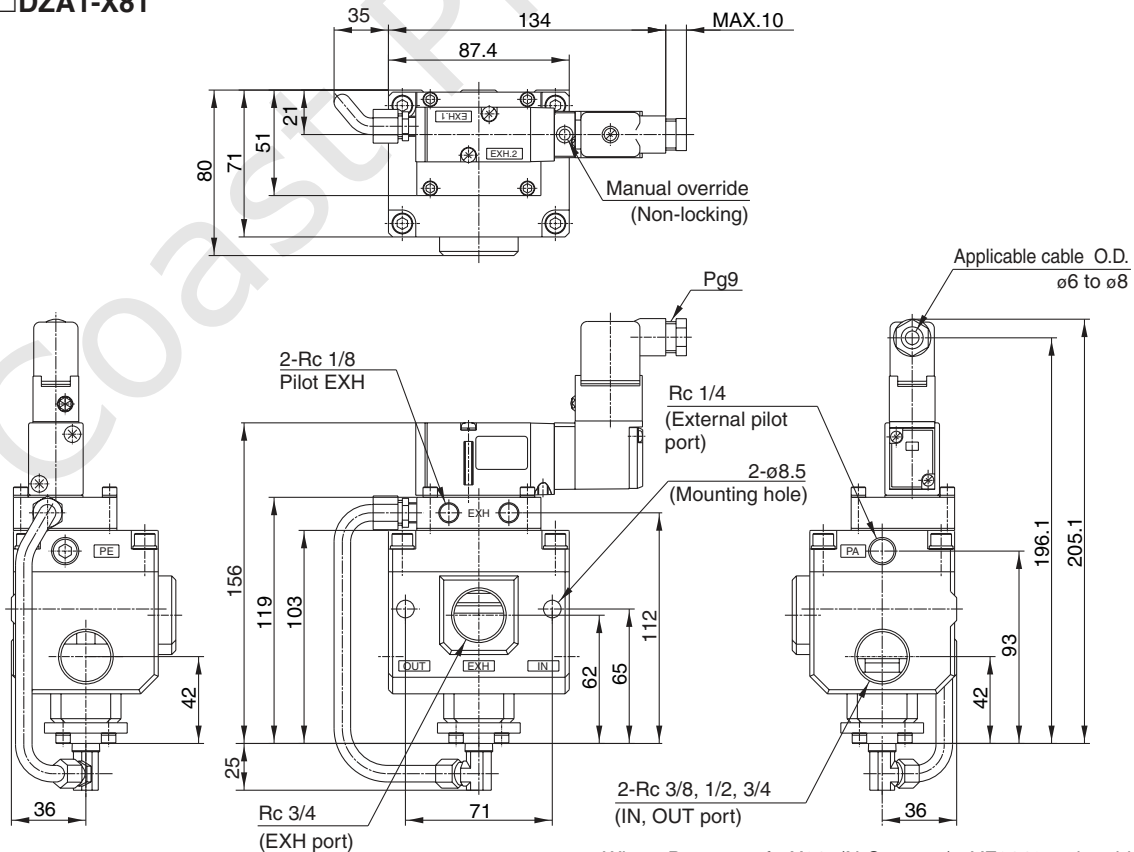

- When B spec. of -X81 (N.O. spec.), VF3140 solenoid has to be positioned at left, when looking at the EXH port in the front face.
 • In the case of -X80, VF3240-□□□ (Pilot valve) will be mounted.

V100

SY

SYJ

VK

VZ

VT

VP

VG

VP

S070

VQ

VKF

VQZ

VZ

VS

VFN

Series VP3145/3165/3185

Dimensions

VP3165-□□DZA1-X81

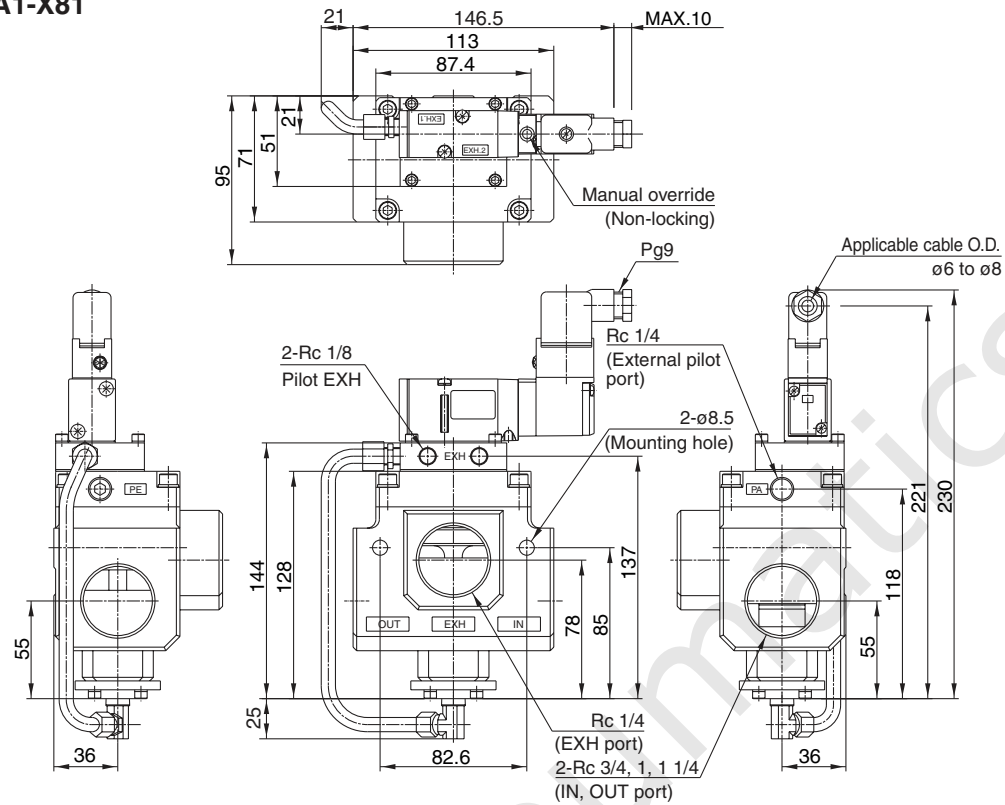

- When B spec. of -X81 (N.O. spec.), VF3140 solenoid has to be positioned at left, when looking at the EXH port in the front face.
- In the case of -X80, VF3240-□□□ (Pilot valve) will be mounted.

VP3185- □□DZA1-X81

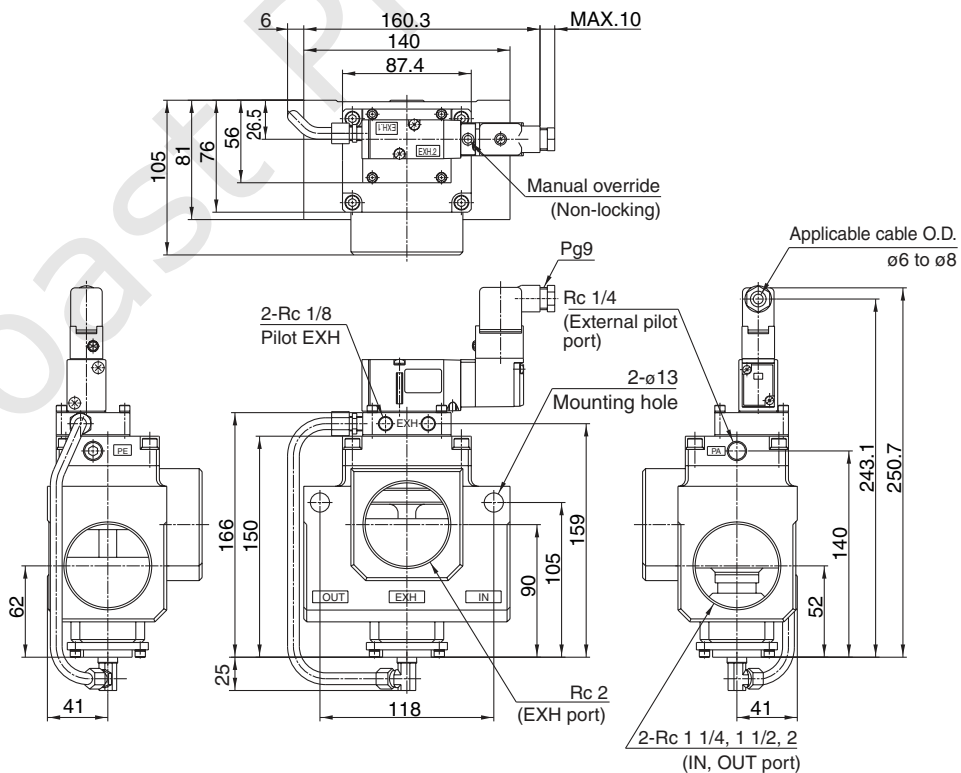

- When B spec. of -X81 (N.O. spec.), VF3140 solenoid has to be positioned at left, when looking at the EXH port in the front face.
- In the case of -X80, VF3240-□□□ (Pilot valve) will be mounted.